



UTILITY SOLUTIONS

POWER(FUL) INNOVATION.™

PRODUCT CATALOG



CONTENTS

INTRODUCTION	6
LOAD BREAK TOOLS	7
LOAD-RANGER® FLEX-LT™	8
BREAK-SAFE®	10
BREAK-SAFE® 600	11
Fuse-Safe™	11
SAFETY & TRAINING	12
Load-Trainer™ II	13
Grounds Tester	14
Overhead Grounds-Trainer™	15
Underground Grounds-Trainer™	16
FIBERGLASS HOT STICKS	17
BLUE STRIPE® Take-Apart Hot Sticks	18
BLUE STRIPE® Telescopic Hot Sticks	19
BLUE STRIPE® Measuring Sticks	20
BLUE STRIPE® Heavy Duty Telescopic Hot Sticks	21
BLUE STRIPE® Heavy Duty Substation Sticks	21
BLUE STRIPE® Shotgun Sticks	22
BLUE STRIPE® Foam Filled Straight Sticks	24
BLUE STRIPE® Link Sticks	26
BLUE STRIPE® Discharge Hook	29
BLUE STRIPE® Rescue Hook	29
BLUE STRIPE® Telescopic Stick Stopper	30
BLUE STRIPE® Telescopic Range Pole	30
Spline Torque Bar	31
BLUE STRIPE® Cleaning Products	31
Protective Bags	32
Bucket Stick Storage Cases	32
Hot Stick Accessories	33
Fuzzy Finger™	33
Quick Grab Probe & Quick Grab Power Probe	34
OVERHEAD DISTRIBUTION	36
Grab-It™	37
Jack Jumper®	38
Conductor Lift Snatch Block	40
OVERHEAD DISTRIBUTION (Continued)	
Tail Tamer™	40
Jumper-T	40
Conductor Cleaning Brush	41
Varmint Shield	41
Expendable Fuse Tube Caps	41
BLUE STRIPE® Heavy Duty Ice Roller	42
Ice Breaker	43
Ice Whacker	43
Jumper Hook	44
Jumper Aid™	44
Jumper Cuff™	44
Blanket Mate	45
Bucket Hook	45
Blanket Clamp	45
KLONDIKE CLAMP®	46
Rex Clamp™	46
UNDERGROUND DISTRIBUTION	47
BLUE STRIPE® Switch Hook Stick	48
BLUE STRIPE® Cable Hook Stick	48
URD Cap Stand™	49
Strip-N-Coil™	49
Padmount Multi-Tool	50
Universal URD Wrench	50
Padmount Hex Adapter Set	50
METERING PRODUCTS	51
Meter Grabber	52
Electric Meter Jumper Leads	52
SERVICES	53
Tool Demonstration Trailers	53
Factory Service	53
TERMS & CONDITIONS	54
VIDEO LIBRARY	55

INTRODUCTION

About Utility Solutions, Inc.

Utility Solutions, Inc. is a designer and manufacturer of hot line tools and products for the electrical power industry. Founded in 1990 by engineers with broad electrical distribution experience, Utility Solutions has accumulated an impressive list of innovative and patented products that directly relate to a lineman's job.

- All of our products are proudly **manufactured in the USA**, at our facility located in Hickory, North Carolina.
- We manufacture tools and products that linemen WANT to use.
- Our product line focuses on safety, reliability and ease of use.
- Each product is designed and built to exceed industry standards and have a long and useful life.
- We are innovators in load break technology, fiberglass construction, materials selection and machining.
- Many products in this catalog were invented by linemen.
- We have the experience, resources and desire to bring new products to market quickly and efficiently.

Our Vision

Through innovation and engineering, we conceive a safer, smarter, more controlled work environment for those who work to deliver power.

Our Why

We are a driven team - guided by engineers and executed by a highly trained, specialized workforce with the combined focus of delivering tools and products manufactured to the highest standards - creating and innovating to safely deliver powerful control to lineworkers and others throughout the power grid.



Made in the USA



WARNING

Verify tool is properly closed prior to use. When using the back jaws, manually extend the jaws at least 2-3 inches and release. The tool will extend quickly, indicating proper use.

Only qualified personnel should operate the Load Breaker® 217 Portable Load Breaker. Personnel should wear appropriate protective equipment in accordance with established site and safety practices.

Carefully read and fully understand the operating manual prior to use. Improper operation, lack of maintenance of this device can result in the potential for personal injury and/or equipment damage.

Do not use this tool on metal equipment unless tool is used with optional extended head. Failure may occur.

STRIPE®
Hot Stick

LOAD BREAK TOOLS

LOAD-RANGER® FLEX-LT™

A Revolutionary New Design

The LOAD-RANGER® FLEX-LT™ is the latest innovation in load break tools. With a patented rotating FLEX head, the innovative design of the LOAD-RANGER® FLEX-LT™ allows a much broader range of operation than traditional load break tools, and greatly reduces or eliminates binding positions and tool stresses while improving flexibility when attaching the tool to an arcing horn.

The LOAD-RANGER® FLEX-LT™ is designed with linemen in mind. Coupled with the rotating FLEX head, the No-Pinch red reset trigger is located prominently on the side of the tool, making it easier to reset while wearing gloves.

All tools are built with heavy duty components that are machined, not cast. The tool has been rigorously tested and will stand up to repeated use. The LOAD-RANGER® FLEX-LT™ is specifically engineered to be inspected and serviced in minutes using only 2 tools, saving time and money.

The LOAD-RANGER® FLEX-LT™ is available in 27 kV and 38 kV models.

FLEX Head

Rotates 180° to significantly reduce binding positions

Lighter Weight

Machined parts offer a lightweight and robust design

Broadest Operation Range

Specially designed to have the broadest operation range of any load break tool available



Standard Overhead Arm

Item Number:	Description:	Maximum Voltage	Maximum Amperage	Weight
USLR-FLEX-1-H	27 kV WITH HARD CASE	27 kV	900 AMP	4 lb 10 oz
USLR-FLEX-1-C-H	27 kV WITH COUNTER & HARD CASE			
USLR-FLEX-2-H	38 kV WITH HARD CASE	38 kV	900 AMP	4 lb 10 oz
USLR-FLEX-2-C-H	38 kV WITH COUNTER & HARD CASE			



27 kV LOAD-RANGER® FLEX-LT™ with counter

Padmount Arm

Item Number:	Description:	Maximum Voltage	Maximum Amperage	Weight
USLR-FLEX-1-P-H	27 kV WITH PADMOUNT ARM, EXTENDED HOOD & HARD CASE	27 kV	900 AMP	5 lb 5 oz
USLR-FLEX-1-C-P-H	27 kV WITH COUNTER, PADMOUNT ARM, EXTENDED HOOD & HARD CASE			



38 kV LOAD-RANGER® FLEX-LT™ without counter

Options:



Hard Case



Counter



Padmount Arm & Extended Hood



Extended Hood

Contact customer service or visit our website for a complete list of options.

BREAK-SAFE®

Load Break & Pick-up Tool

The patented BREAK-SAFE® is designed to add a functional and portable switch to a mechanical jumper. The BREAK-SAFE® has three operating functions:

- Load Break
- Continuous Current Duty
- Load Pick-Up

In order to keep personnel at a safe distance, the BREAK-SAFE® is operated with an insulated fiberglass hot stick for load break and load pick-up functions. The Yellow Safety Lock is also operated by a hot stick and helps prevent the tool from an unintended load break or pickup operation.

The BREAK-SAFE® is available in four models with either a Floating Head or a Duckbill:

- 15 kV / 300 amp
- 27 kV / 300 amp
- 38 kV / 300 amp
- 46 kV / 200 amp

Duckbill



Floating Head



Item Number:	Description:	System Voltage	Rating*	Weight	Closed Length	Open Length	Conductor Size	Diameter
USBS-15-1-PS	15 kV WITH FLOATING HEAD	15 kV	300 AMP	7 lb 3 oz	24"	28"	#6 COPPER MIN. Up to 954 ACSR (1.1" Dia.) MAX	2.5" Dia.
USBS-15-2-PS	15 kV WITH DUCKBILL HEAD	15 kV	300 AMP	6 lb 3 oz	28"	32"		
USBS-27-1-PS	27 kV WITH FLOATING HEAD	27 kV	300 AMP	7 lb 10 oz	28"	33.5"		
USBS-27-2-PS	27 kV WITH DUCKBILL HEAD	27 kV	300 AMP	7 lb	32"	37.5"		
USBS-38-1-PS	38 kV WITH FLOATING HEAD	38 kV	300 AMP	8 lb 6 oz	33"	41"		
USBS-38-2-PS	38 kV WITH DUCKBILL HEAD	38 kV	300 AMP	7 lb 12 oz	37"	45"		
USBS-46-1-PS	46 kV WITH FLOATING HEAD	46 kV	200 AMP	10 lb 3 oz	42.5"	53.5"		
USBS-46-2-PS	46 kV WITH DUCKBILL HEAD	46 kV	200 AMP	9 lb 9 oz	46.5"	57.5"		

* LOAD BREAK, LOAD PICK-UP, CONTINUOUS CURRENT DUTY

Options:



Item number:
USBS-XX-X-PS-S
OPTIONAL SOFT CASE



Item number:
USBS-XX-X-PS-H
OPTIONAL HARD CASE



BREAK-SAFE® 600

Rated 27 kV/600 amps



The BREAK-SAFE® 600 is a portable switch rated 27 kV / 600 amps for high current applications such as Load Break, Load Pick-Up, and Continuous Current Duty.

The extra large clamp is capable of handling all wire sizes up to nearly 3.5" diameter. Dual conductor bars allow parallel jumpers to reach the 600 amp rating.

Item Number:	Description:	System Voltage	Rating	Weight	Closed Length	Open Length	Conductor Size
USBS-600-1	600 AMP WITH FLOATING HEAD	27 kV	600 AMP	12 lb 3 oz	33"	40.5"	up to 3.5" dia.

Options:



Item Number: -S
OPTIONAL SOFT CASE

Fuse-Safe™

Portable Current-Limiting Fuse And Fault Protection



The Fuse-Safe™ is a portable current-limiting fuse and fault protection tool. It offers better protection than temporary cutouts, and is easier to install. The Fuse-Safe™ can also add fault protection to our BREAK-SAFE® Load Break and Pick-up Tools.

Available as a single unit with or without a fuse or as a complete 3-phase kit. Contact customer service or visit our website for a complete list of fuse selections.

Item Number:	Description:
USFS-001	DUCKBILL W/ 5/8" DIA. CONDUCTOR BAR (FUSE SOLD SEPERATELY)
USFS-002	5/8" CONDUCTOR BAR WITH CUSTOMER SPECIFIED FUSE INCLUDED
USFS-002-KIT-1	THREE ASSEMBLED USFS-001 UNITS, EACH CONTAINING 15.5 kV & 25 AMP CURRENT LIMITING FUSES (T&B # HTFX240025) WITH HARD CASE*
USFS-003	DUCKBILL W/ 3/8" DIA. CONDUCTOR BAR (FUSE SOLD SEPERATELY)
USFS-004	DUCKBILL W/ 3/8" DIA. CONDUCTOR BAR WITH CUSTOMER SPECIFIED FUSE

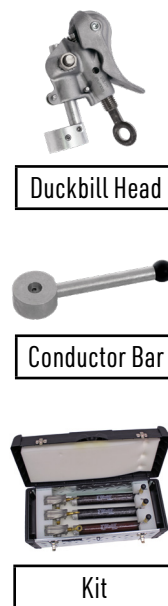

Duckbill Head

Conductor Bar

Kit

*Contact factory for fuse options.

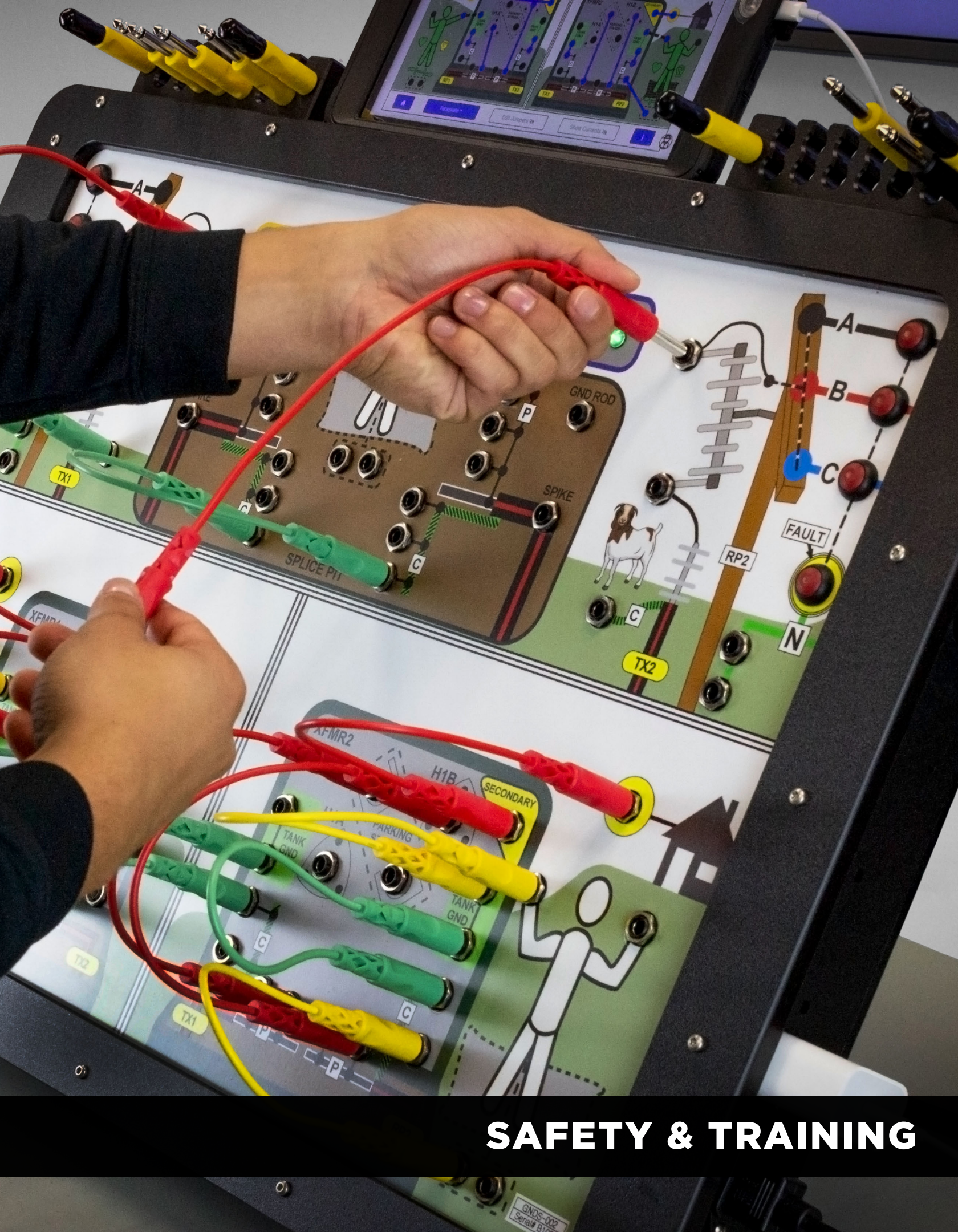

SAFETY & TRAINING

GND5-002
Serial Blot

Load-Trainer™ II

Transformer Simulator

The Load-Trainer™ II provides an immersive learning experience for transformer banking and 3 phase simulation. Real-time information is displayed when the 'TEST' button is pressed.

Demonstrate complex concepts in electrical distribution systems:

- Wye/Delta Configurations
- Open vs Closed Banks
- Multiple Secondary Voltage Options
- Troubleshooting Practice
- Transformer Polarity
- Phase Rotation
- Secondary Backfeed Hazards
- Floating Neutral Configurations

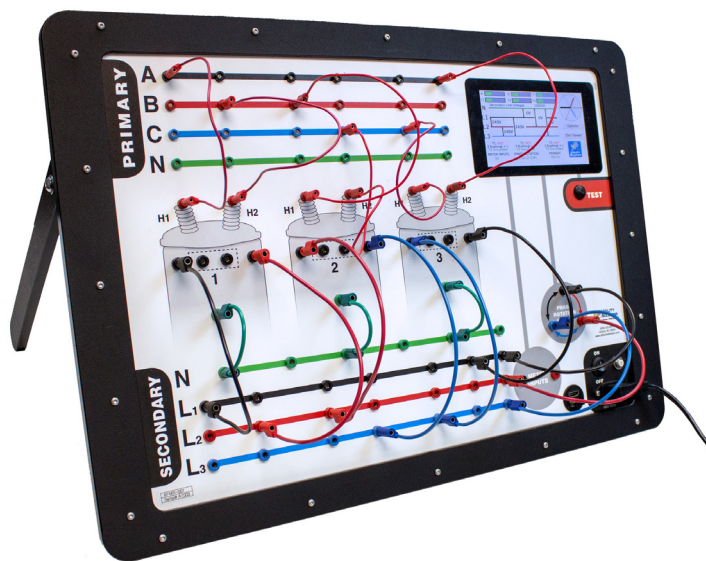

Item Number:	Description:
XFMR-001-H	TRANSFORMER SIMULATOR WITH HARD CASE
XFMR-001-S	TRANSFORMER SIMULATOR WITH SOFT CASE
XFMR-001-LEADSET	TRANSFORMER SIMULATOR EXTRA SET OF COLOR CODED PATCH CORDS

Trainer Measurements: 27.5" Wide x 19" Tall x 3.5" Deep, Weight: 17 lb
 Case Measurements: 31" Wide x 22" Tall x 8.5" Deep, Weight: 21 lb

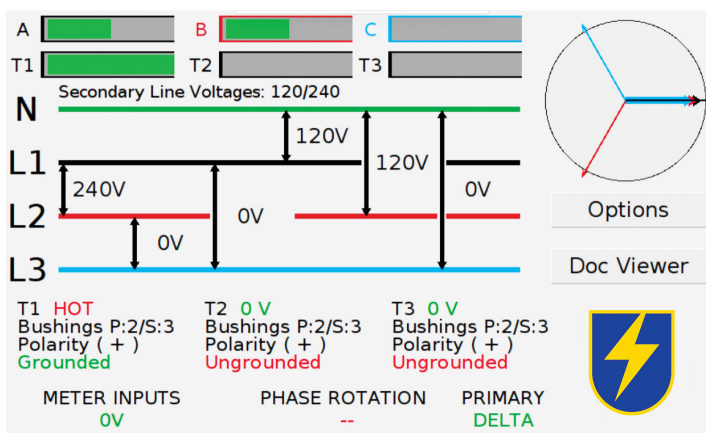

Grounds Tester

High Current, 600 amp AC Voltage Grounds Tester

The Grounds Tester utilizes a voltage (AC) at high current to measure voltage drop across personal grounding equipment. Pass/fail determinations are made by comparing the voltage drop to convenient charts in the manual and on the case lid.

Equipped with REACH™ technology and an integrated voltmeter, a ground assembly can be tested at various points to quickly troubleshoot defects in the assembly.

The Grounds Tester can evaluate cable sizes from #2 to double 4/0 and plugs into a standard 120V, 15 amp receptacle and includes thermal overload protection. Optional adapters are available from Utility Solutions for use with the Grounds Tester.



Product Dimension: 20" Width x 15" Tall x 7.5" Depth
Product Weight: 50 lb



Item Number:	Description:
USGT-600	PROTECTIVE GROUND TESTER
USGT-600-15KVBUSHING	15 kV LOADBREAK BUSHING ADAPTER
USGT-600-15KVELBOW	15 kV LOADBREAK ELBOW ADAPTER
USGT-600-27KVBUSHING	27 kV LOADBREAK BUSHING ADAPTER
USGT-600-27KVELBOW	27 kV LOADBREAK ELBOW ADAPTER
USGT-600-SUB	3 1/8" OD SUBSTATION CLAMP ADAPTER



15 kV LOAD BREAK BUSHING ADAPTER



15 kV LOAD BREAK ELBOW ADAPTER



27 kV LOAD BREAK BUSHING ADAPTER



27 kV LOAD BREAK ELBOW ADAPTER



3 1/8" OD SUBSTATION CLAMP ADAPTER

Overhead Grounds-Trainer™

Personal Protective Grounding Simulator

The Overhead Grounds-Trainer™ provides an immersive learning experience for complex concepts. The simulator also allows for recreating field scenarios using interactive disconnect switches and source buttons.

Demonstrate complex concepts:

- Distribution of Fault Currents
- Ground Potential Rise
- Step & Touch Potential
- Soil Resistivity
- Resistance of Personal Protective Ground Sets (PPG)

Real world variables:

- System Voltages
- PPG & Connection Quality
- Soil Type & Temperature
- Broken Conductors
- Induction
- Backfeed

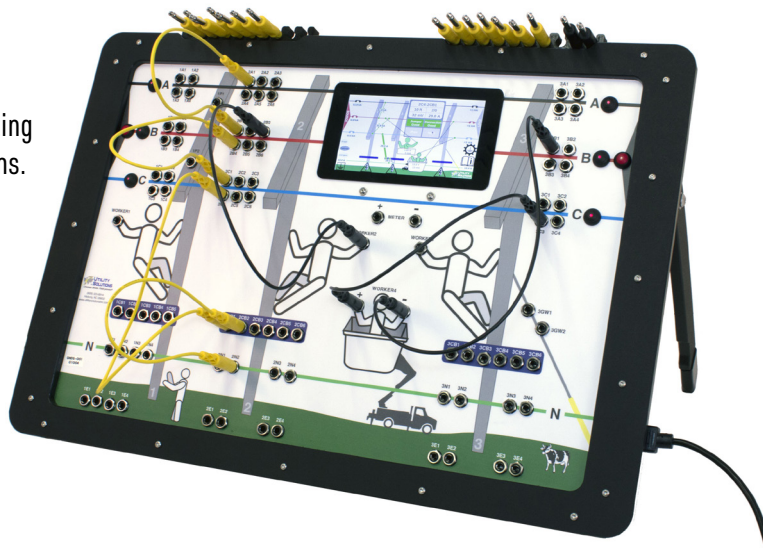

Configure multiple grounding styles and work methods:

- Shunt vs Umbrella Configurations
- Single Point Grounding
- Bracket Grounding
- Equipotential Zone Grounding (EPZ)
- Equipment Grounding
- Parallel Grounds

Item Number:	Description:
GNDS-001-H	OVERHEAD GROUNDS-TRAINER™ SIMULATOR WITH HARD CASE
GNDS-001-S	OVERHEAD GROUNDS-TRAINER™ SIMULATOR WITH SOFT CASE
GNDS-001-LEADSET	OVERHEAD GROUNDS-TRAINER™ SIMULATOR SET OF LEADS

Trainer Measurements: 27.5" Wide x 19" Tall x 3.5" Deep , weight: 18 lb
Case Measurements: 31" Wide x 22" Tall x 8.5 Deep, Weight: 21 lb

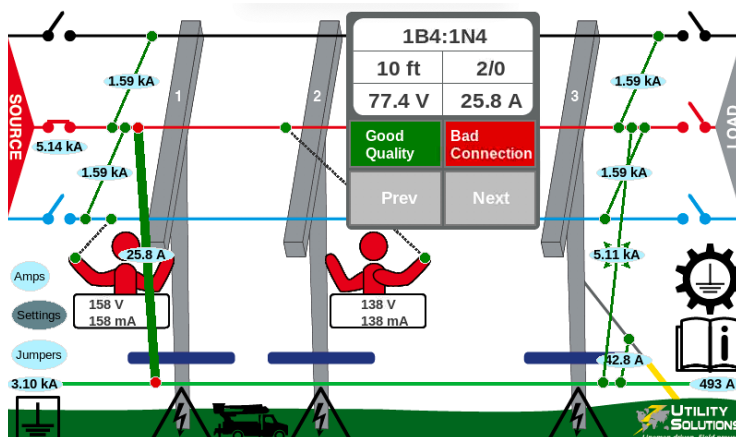

Underground Grounds-Trainer™

Personel Protective Grounding Simulator

The Underground Grounds-Trainer™ uses our unique PhaseLink™ technology to combine a physical wiring environment with computer-controlled and WiFi-enabled simulation software. In addition to installing jumpers, users can connect wirelessly to the unit to create and observe real-time results of concepts and field scenarios like never before.

The simulator also features interactive disconnect switches, source buttons, and an included 10.2" iPad which wirelessly connects to the unit, allowing instructors ultimate freedom and flexibility.



Demonstrate complex concepts:

- Radial vs Loop Circuits
- Basic Switching and Phasing
- Neutral Currents & Total Isolation
- Ground Potential Rise
- Step & Touch Hazards
- Cable ID & Verification

Real world variables:

- PPG & Connection Quality
- URD Cable & Overhead Faults
- Soil Type & Temperature
- Secondary Backfeed Hazards

Configure multiple grounding styles and work methods:

- Radial, Open & Closed Loop Circuits
- Grounding Transformers & Riser
- Equipotential Zone Grounding (EPZ)

Item Number:	Description:
GNDS-002-H	UNDERGROUND GROUNDS-TRAINER™ SIMULATOR WITH HARD CASE
GNDS-002-LEADSET	UNDERGROUND GROUNDS-TRAINER™ SET OF LEADS

Trainer Measurements: 27.5" Wide x 19" Tall x 3.5" Deep , weight: 18 lb
Case Measurements: 31" Wide x 22" Tall x 8.5 Deep, Weight: 21 lb

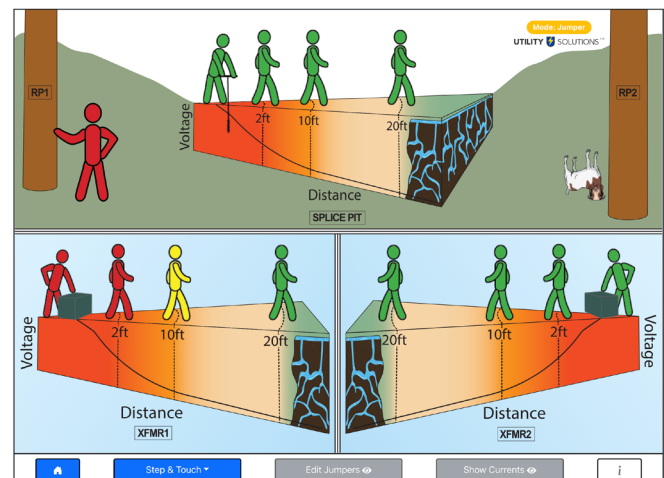
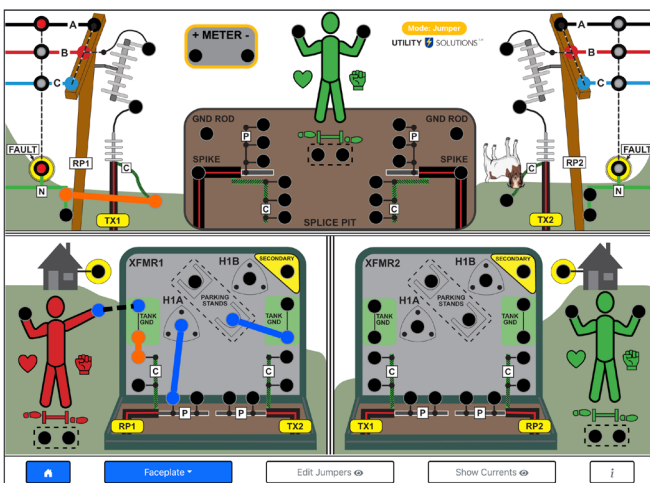



FIBERGLASS HOT STICKS



Scan for more information.

The BLUE STRIPE® Fiberglass Hot Stick line is the latest evolution in sticks. We have incorporated several advanced features that make them safe, dependable, easily maintained and lineman friendly. Most of our BLUE STRIPE® Fiberglass Hot Sticks are available in customized lengths. Contact customer service at 828-323-8914 for more information about how to order customized stick lengths. For more information and detailed specs on the BLUE STRIPE® line, please scan the QR Code to visit our website.

All BLUE STRIPE® Fiberglass Sticks are manufactured to meet industry standards including OSHA, ASTM and IEC as applicable.

BLUE STRIPE® Take-Apart Hot Sticks

Telescoping Hot Sticks with Interlocking, Removable Sections



The industry's first round, telescopic hot stick with removable sections. The same premium BLUE STRIPE® Fiberglass Hot Stick technology now with patented interlocking sections for easy removal. Removable sections offer versatility and easy maintenance, without binding or sticking. The CNC machined "no pinch" buttons are durable and easy to operate.

Ground Operable (Tip Lock)

Item Number:	Size:		Closed Length:	Weight:	Protective Bag:
USTS-TA-016	16'	4.9 m	61"	4 lb	USSB-008
USTS-TA-020	20'	6.2 m	63"	5 lb	
USTS-TA-025	25'	7.6 m	64"	7 lb	
USTS-TA-030	30'	9.1 m	66"	9 lb	USSB-006
USTS-TA-035	35'	10.6 m	68"	11 lb	
USTS-TA-040	40'	12.2 m	69"	13.5 lb	
USTS-TA-045	45'	13.7 m	71"	16.5 lb	

Bucket Operable (Non Tip Lock)

Item Number:	Size:		Closed Length:	Weight:	Protective Bag:
USTS-TA-008	8'	2.4 m	28.5"	2.25 lb	USSB-003 / USSB-001
USTS-TA-010	10'	3 m	30"	3 lb	
USTS-TA-012	12'	3.7 m	32"	4 lb	



Options:



Item number:
USTS-TA-XXX-N
NON-TIP LOCK
(GROUND OPERABLE ONLY)



Item number:
USTS-TA-XXX-BOOT
HEAVY DUTY RUBBER BOOT
(AVAILABLE ON 8' TO 45' SIZES)

BLUE STRIPE® Telescopic Hot Sticks

Telescoping Hot Sticks with Easy Alignment Feature



BLUE STRIPE® Fiberglass Hot Sticks are made with Epoxy resin, the superior choice for making hot sticks. Our sticks have excellent dielectric properties and resistance to water absorption, are easier to clean, and easier to repair. The Easy Tip Lock Replacement feature allows button replacement without sacrificing the foam-filled tip section, while the BLUE STRIPE® alignment feature helps to locate the CNC machined buttons.

Ground Operable (Tip Lock)

Item Number:	Size:		Closed Length:	Base Diameter:	No. of Sections:	Weight:	Operating Lengths:	Protective Bag:
USTS-016	16'	4.9 m	56"	1.2"	4	4 lb	16', 12'	USSB-005
USTS-020	20'	6.2 m	58"	1.9"	5	5 lb 3 oz	21', 17'	
USTS-025	25'	7.6 m	60"	2.1"	6	6 lb 14 oz	26', 21', 17'	
USTS-030	30'	9.1 m	62"	2.3"	7	8 lb 14 oz	30', 26', 21', 17'	USSB-008
USTS-035	35'	10.6 m	63"	2.6"	8	11 lb	35', 30', 26', 21', 17'	
USTS-040	40'	12.2 m	65"	2.9"	9	13 lb 8 oz	40', 35', 30', 26', 21'	
USTS-045	45'	13.7 m	66"	3.1"	10	16 lb 8 oz	45', 40', 35', 30', 26'	USSB-006
USTS-050	50'	15.2 m	68"	3.5"	11	20lb	50', 45', 40', 35', 30'	
USTS-055	55'	16.8 m	69.5"	3.7"	12	25 lb 4 oz	55', 50', 45', 40', 35'	

Bucket Operable (Non Tip Lock)

Item Number:	Size:		Closed Length:	Base Diameter:	No. of Sections:	Weight:	Operating Lengths:	Protective Bag:
USTS-004	4'	1.2 m	26"	1.6"	3	2 lb	4'	USSB-003
USTS-006	6'	1.8 m	26"	1.9"	4	2 lb 8 oz	6'	
USTS-008	8'	2.5 m	26"	2.1"	5	3 lb 11 oz	8'	
USTS-010	10'	3 m	28"	2.4"	6	4 lb 11 oz	10'	
USTS-012	12'	3.7 m	30"	2.6"	7	5 lb 11 oz	12'	

Item Number:	Size:		Closed Length:	Base Diameter:	No. of Sections:	Weight:	Operating Lengths:	Protective Bag:
USSA-ETE	5'	1.5 m	56"	1.3"	1	1 lb	adds 56"	USSB-005

Options:



Item number:
USTS-XXX-BOOT
HEAVY DUTY RUBBER BOOT
(AVAILABLE ON 6' UP TO 45' SIZES)



Item number:
USTS-XXX-N
NON-TIP LOCK
(GROUND OPERABLE ONLY)

**BLUE STRIPE®
Measuring Sticks**

Easy Eye-Level Measuring



An all-in-one Measuring Stick and BLUE STRIPE® Hot Stick. The BLUE STRIPE® Measuring Sticks offer easy eye-level measuring while also functioning as fully-rated telescopic hot sticks. Large, clear English and Metric measurements are available.

Standard Measuring Sticks (Non Tip Lock)

Item Number English:	Item Number Metric:	Size:		Closed Length:	Weight:	Protective Bag
USTS-016-EM	USTS-016-MM	16'	4.9 m	56"	4 lb	USSB-005
USTS-020-EM	USTS-020-MM	20'	6.2 m	58"	5 lb 3 oz	
USTS-025-EM	USTS-025-MM	25'	7.6 m	60"	6 lb 14 oz	
USTS-030-EM	USTS-030-MM	30'	9.1 m	62"	8 lb 14 oz	USSB-008
USTS-035-EM	USTS-035-MM	35'	10.6 m	63"	11 lb	
USTS-040-EM	USTS-040-MM	40'	12.2 m	65"	13 lb 8 oz	
USTS-045-EM	USTS-045-MM	45'	13.7 m	66"	16 lb 8 oz	
USTS-050-EM	USTS-050-MM	50'	15.2 m	68"	20 lb	USSB-006

Standard Measuring Stick Options:



Item number:
USTS-XXX-XX-PHE
PLASTIC HOOK END



Item number:
USTS-XXX-XX-TL
TIP LOCK



Item number:
USTS-XXX-XX-BOOT
HEAVY DUTY RUBBER BOOT
(AVAILABLE ON
6' UP TO 45' SIZES)

Take Apart Measuring Sticks (Tip Lock)

Item Number English:	Item Number Metric:	Size:		Closed Length:	Weight:	Protective Bag
USTS-TA-035-EM	USTS-TA-035-MM	35'	10.7 m	68"	11 lb	USS-006
USTS-TA-040-EM	USTS-TA-040-MM	40'	12.2 m	69"	13.5 lb	
USTS-TA-045-EM	USTS-TA-045-MM	45'	13.7 m	71"	16.5 lb	

Take Apart Measuring Stick Options:



Item number:
USTS-TA-XXX-XX-PHE
PLASTIC HOOK END



Item number:
USTS-TA-XXX-XX-TL
TIP LOCK



Item number:
USTS-TA-XXX-XX-BOOT
HEAVY DUTY RUBBER BOOT
(AVAILABLE ON
6' UP TO 45' SIZES)

BLUE STRIPE® Heavy Duty Telescopic Hot Sticks

Telescoping Hot Sticks Featuring Added Rigidity



Designed for heavy duty pulling, pushing and twisting operations, the BLUE STRIPE® Heavy Duty Telescopic Hot Sticks features a 1.1" diameter first section to provide additional strength. The machined spline end assembly is securely fastened to the handle for higher torque application.

Item Number:	Size:	Closed Length:	Operating Lengths:	Weight:	Protective Bag:
USTS-HD-016	16'	56"	16', 12'	5 lb 15 oz	USSB-005
USTS-HD-020	20'	58"	21', 17'	7 lb 10 oz	
USTS-HD-025	25'	60"	26', 21', 17'	9 lb 10 oz	
USTS-HD-030	30'	62"	30', 26', 21', 17'	11 lb 12 oz	USSB-008
USTS-HD-035	35'	63"	35', 30', 26', 21', 17'	14 lb 4 oz	
USTS-HD-040	40'	65"	40', 35', 30', 26', 21'	17 lb 4 oz	
USTS-HD-045	45'	68"	45', 40', 35', 30', 26'	19 lb 8 oz	USSB-006
USTS-HD-050	50'	69.5"	50', 45', 40', 35', 30'	24 lb 12 oz	

Options:



Item number: USTS-HD-XXX-BOOT
HEAVY DUTY RUBBER BOOT (ONLY AVAILABLE ON 16' TO 50' SIZES)

BLUE STRIPE® HEAVY DUTY SUBSTATION STICKS

Built for Heavy Duty Substation Applications



BLUE STRIPE® Substation Sticks are robust, compact and built for heavy duty substation applications. All Heavy Duty Substation sticks now come standard with a robust Rubber Boot.



DUAL BUTTON DESIGN

Key features include:

- Dual Button Design for Added Strength
- High Performance Closed Cell Foam Filled Inner Section
- Compact Telescopic Design
- BLUE STRIPE® Alignment Feature

Item Number :	Description:	No. of Sections:	Operating Lengths:	Collapsed Length:	Diameter:	Weight:
USTS-H02-DH-BOOT	DISCONNECT HEAD	2	13', 12', 11', 10'	7' 6"	Inner: 1.25" Outer: 1.5"	6 lb
USTS-H02-SE-BOOT	SPLINE END WITH HOT STICK PROBE					
USTS-H02-SH-BOOT	SWITCH HEAD					
USTS-H02-QC-BOOT	QUICK CONNECT HEAD					
USTS-H03-DH-BOOT	DISCONNECT HEAD	3	18' 6", 17' 6", 16' 6", 15' 6", 13' 3", 12' 3", 11' 3", 10' 3"	7' 8"	Inner: 1.25" Middle: 1.5" Outer: 1.75"	9 lb
USTS-H03-SE-BOOT	SPLINE END, HOT STICK PROBE					
USTS-H03-SH-BOOT	SWITCH HEAD					
USTS-H03-QC-BOOT	QUICK CONNECT HEAD					



DISCONNECT HEAD



SPLINE END WITH HOT STICK PROBE



SWITCH HEAD



QUICK CONNECT HEX HEAD

**BLUE STRIPE®
Shotgun Sticks**

Innovative STRIPE UP, HOOK DOWN® Feature

All BLUE STRIPE® Shotgun Sticks are available with two distinct operating handle orientations. The variations include a version with a side button (Standard) with the hook pivoting down and a bottom break hook (BBH) version. The bottom break hook option aligns the button and hook on the same plane for those who prefer "button up, hook down" functionality.

Standard BLUE STRIPE® Shotgun Sticks



Bottom Break Hook BLUE STRIPE® Shotgun Sticks



**BLUE STRIPE®
Shotgun Sticks**

Internal and External Rod Options



BLUE STRIPE® Shotgun Sticks are available in both internal and external rod, from 4' to 12'. Various end fitting configurations are available. Our BLUE STRIPE® Shotgun Sticks offer an innovative STRIPE UP, HOOK DOWN® feature. When the stripe is up, the stainless steel hook opens downward, minimizing accidental drops.

With Rubber End Cap (EC)



Internal Rod:	External Rod:	Size:		Weight:	Bag:
USSG-004-IREC	USSG-004-EREC	4' 6"	1.4 m	4 lb 4 oz	USSB-005
USSG-006-IREC	USSG-006-EREC	6' 6"	2 m	5 lb 3 oz	USSB-007
USSG-008-IREC	USSG-008-EREC	8' 6"	2.6 m	5 lb 14 oz	USSB-009
USSG-010-IREC	USSG-010-EREC	10' 6"	3.2 m	6 lb 13 oz	USSB-011
USSG-012-IREC	USSG-012-EREC	12' 6"	3.8 m	9 lb 8 oz	USSB-012

With Spline End (SE)



Internal Rod:	External Rod:	Size:		Weight:	Bag:
USSG-004-IRSE	USSG-004-ERSE	4' 7.5"	1.4 m	4 lb 8 oz	USSB-005
USSG-006-IRSE	USSG-006-ERSE	6' 7.5"	2 m	5 lb 7 oz	USSB-007
USSG-008-IRSE	USSG-008-ERSE	8' 7.5"	2.6 m	6 lb 2 oz	USSB-009
USSG-010-IRSE	USSG-010-ERSE	10' 7.5"	3.2 m	7 lb 1 oz	USSB-011
USSG-012-IRSE	USSG-012-ERSE	12' 7.5"	3.8 m	9 lb 12 oz	USSB-012

With 1/2" Female Socket Adapter End (FA)



Internal Rod:	External Rod:	Size:		Weight:	Bag:
USSG-004-IRFA	USSG-004-ERFA	4' 7"	1.4 m	4 lb 14 oz	USSB-005
USSG-006-IRFA	USSG-006-ERFA	6' 7"	2 m	5 lb 13 oz	USSB-007
USSG-008-IRFA	USSG-008-ERFA	8' 7"	2.6 m	6 lb 8 oz	USSB-009
USSG-010-IRFA	USSG-010-ERFA	10' 7"	3.2 m	7 lb 7 oz	USSB-011
USSG-012-IRFA	USSG-012-ERFA	12' 7"	3.8 m	10 lb 2 oz	USSB-012

With Quick Connect Hex Head End (QC)

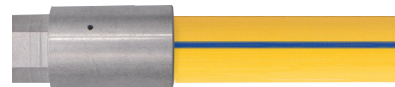

Internal Rod:	External Rod:	Size:		Weight:	Bag:
USSG-004-IRQC	USSG-004-ERQC	4' 7.25"	1.4 m	4 lb 8 oz	USSB-005
USSG-006-IRQC	USSG-006-ERQC	6' 7.25"	2 m	5 lb 7 oz	USSB-007
USSG-008-IRQC	USSG-008-ERQC	8' 7.25"	2.6 m	6 lb 2 oz	USSB-009
USSG-010-IRQC	USSG-010-ERQC	10' 7.25"	3.2 m	7 lb 1 oz	USSB-011
USSG-012-IRQC	USSG-012-ERQC	12' 7.25"	3.8 m	9 lb 12 oz	USSB-012

Options:



Item number: USSA-HG1
HAND GUARD

Item number: USSG-XXX-XXXX-BBH
BLUE STRIPE® SHOTGUN STICK WITH BOTTOM BREAK HOOK

BLUE STRIPE® Foam Filled Straight Sticks

Straight Sticks Designed to Withstand Daily Use

All Utility Solutions straight sticks are manufactured from the highest quality electrical grade fiberglass and have the mechanical strength to meet the rigors of daily use. Each stick includes a convenient adjustable hanger and has an interior filled with a high-performance closed cell foam to prevent water absorption.

Custom sticks are available in any size and combination of end attachments. Contact customer service or your representative for more information about customized straight sticks.

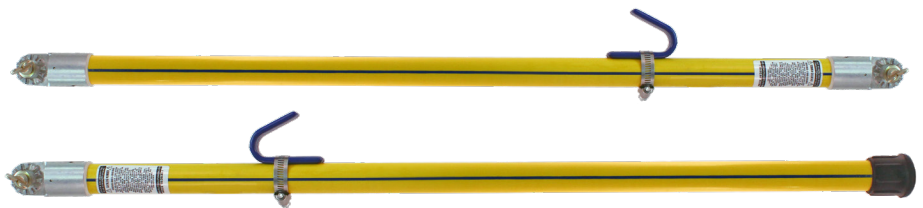

BLUE STRIPE® Universal Straight Sticks



SPLINE END



RUBBER CAP

Item Number :	Ends:	Size:		Diameter:	Bag:
USSS-S-104	SPLINE END & RUBBER CAP	4'	1.2 m	1.25"	USSB-005
USSS-S-106		6'	1.8 m		USSB-006
USSS-S-108		8'	2.5 m		USSB-010
USSS-S-110		10'	3 m		USSB-011
USSS-S-112		12'	3.7 m		USSB-012
USSS-H-104		4'	1.2 m		1.5"
USSS-H-106		6'	1.8 m	USSB-006	
USSS-H-108		8'	2.5 m	USSB-010	
USSS-H-110		10'	3m	USSB-011	
USSS-H-112		12'	3.7m	USSB-012	

Item Number :	Ends:	Size:		Diameter:	Bag:
USSS-S-204	SPLINE ENDS	4'	1.2 m	1.25"	USSB-005
USSS-S-206		6'	1.8 m		USSB-006
USSS-S-208		8'	2.5 m		USSB-010
USSS-S-210		10'	3 m		USSB-011
USSS-S-212		12'	3.7 m		USSB-012
USSS-H-204		4'	1.2 m		1.5"
USSS-H-206		6'	1.8 m	USSB-006	
USSS-H-208		8'	2.5 m	USSB-010	
USSS-H-210		10'	3 m	USSB-011	
USSS-H-212		12'	3.7 m	USSB-012	



BLUE STRIPE® Disconnect Head Sticks

Item Number :	Size:		Diameter:	Bag:
USSS-004-EC/DH	4 ft	1.2 m	1.25"	USSB-005
USSS-006-EC/DH	6 ft	1.8 m		USSB-006
USSS-008-EC/DH	8 ft	2.5 m		USSB-010
USSS-010-EC/DH	10 ft	3 m		USSB-011
USSS-012-EC/DH	12 ft	3.7 m		USSB-012
USSS-H06-EC/DH	6'	1.8 m	1.5"	USSB-006
USSS-H08-EC/DH	8'	2.5 m		USSB-010
USSS-H10-EC/DH	10'	3 m		USSB-011
USSS-H12-EC/DH	12'	3.7 m		USSB-012



BLUE STRIPE® Switch Head Sticks

Item Number :	Size:		Diameter:	Bag:
USSS-004-EC/SH	4'	1.2 m	1.25"	USSB-005
USSS-006-EC/SH	6'	1.8 m		USSB-006
USSS-008-EC/SH	8'	2.5 m		USSB-010
USSS-010-EC/SH	10'	3 m		USSB-011
USSS-012-EC/SH	12'	3.7 m		USSB-012
USSS-H06-EC/SH	6'	1.8 m	1.5"	USSB-006
USSS-H08-EC/SH	8'	2.5 m		USSB-010
USSS-H10-EC/SH	10'	3 m		USSB-011
USSS-H12-EC/SH	12'	3.7m		USSB-012



BLUE STRIPE® Insulated Head Sticks

Item Number :	Size:		Diameter:	Bag:
USSS-004-EC/IH	4 ft	1.2 m	1.25"	USSB-005
USSS-006-EC/IH	6 ft	1.8 m		USSB-006
USSS-008-EC/IH	8 ft	2.5 m		USSB-010
USSS-010-EC/IH	10 ft	3 m		USSB-011
USSS-012-EC/IH	12 ft	3.7 m		USSB-012

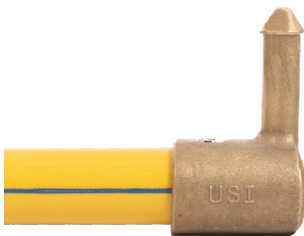

DISCONNECT HEAD

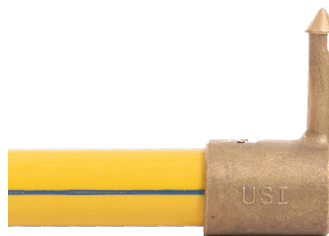

SWITCH HEAD



INSULATED HEAD

BLUE STRIPE® Link Stick

Swivel Eye, Hook & Swivel Eye, Hot Stick Operable Hook & Swivel Eye

BLUE STRIPE® Link Sticks are available in various configurations. The Swivel Eye, Hook & Swivel Eye, and Hot Stick Operable Hook & Swivel Eye are load rated to 4,000 lbs. and feature 1.25" diameter foam filled fiberglass.

Applications include:

- Insulating strap hoists while tensioning lines.
- Insulating bucket jib while lifting or pulling lines.



BLUE STRIPE® Link Stick with Swivel Eyes

Item Number :	Fiberglass Length:		Diameter:	Load Limit:
USLS-006-SWVL	6"	.2 m	1.25"	4,000 lb
USLS-012-SWVL	12"	.3 m		
USLS-015-SWVL	15"	.4 m		
USLS-018-SWVL	18"	.5 m		
USLS-024-SWVL	24"	.6 m		



BLUE STRIPE® Link Stick with Safety Hook & Swivel Eye

Item Number :	Fiberglass Length:		Diameter:	Load Limit:
USLS-006-HOOK	6"	.2 m	1.25"	4,000 lb
USLS-012-HOOK	12"	.3 m		
USLS-015-HOOK	15"	.4 m		
USLS-018-HOOK	18"	.5 m		
USLS-024-HOOK	24"	.6 m		



BLUE STRIPE® Link Stick with Stick Operable Safety Hook & Swivel Eye

Item Number :	Fiberglass Length:		Diameter:	Load Limit:
USLS-006-STOP	6"	.2 m	1.25"	4,000 lb
USLS-012-STOP	12"	.3 m		
USLS-015-STOP	15"	.4 m		
USLS-018-STOP	18"	.5 m		
USLS-024-STOP	24"	.6 m		

Next-level Performance

Removes the complexity from operating a safety hook with a hot stick.

CNC Machined Parts

Machined parts offer a higher quality than cast metal, allowing for longer lasting operation.

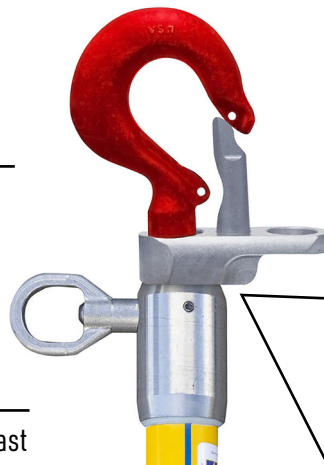

Uniquely Designed

Patent Pending design automatically charged and "locks" into place when aligned with the hook.

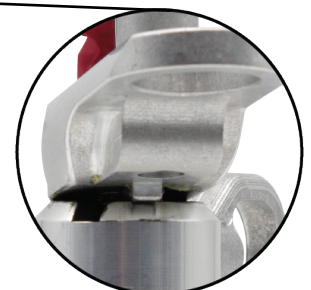
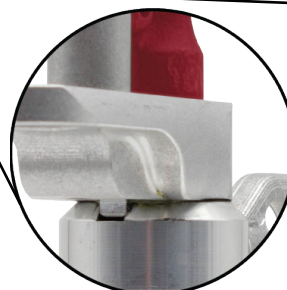

BLUE STRIPE® Link Stick

Crossarm & Swivel Eye

The BLUE STRIPE® Link Stick with Crossarm & Swivel Eye is load rated to 1,500 lbs., constructed from 1.25" diameter foam filled fiberglass and can be installed or removed via hot stick.

Applications include:

- Insulating strap hoists while tensioning lines.
- Fitting directly around crossarms, eliminating the need to install a sling in order to create an attachment point.



Item Number :	Fiberglass Length:		Diameter:	Hook Size:	Load Limit:
USLS-022-XARM	22"	.6 m	1.25"	5" (Fits crossarms up to 3.75" x 4.75")	1,500 lb

BLUE STRIPE® Link Stick

Pigtail Hook & Swivel Eye, Heavy Duty Pigtail & Swivel Eye

The BLUE STRIPE® Link Stick with Pigtail and Swivel Eye features 1.25" diameter foam filled fiberglass, and can be installed or removed via hot stick.

Applications include:

- Pulling and lifting line spans for creating work clearance or repositioning phases.
- Allows quick installation onto line without needing to operate a latch.
- Quicker installation than a regular hook in situations where a true positive lock is not necessary.



Item Number :	Fiberglass Length:		Diameter:	Load Limit:	Conductor Size:
USLS-006-PIG	6"	.2 m	1.25"	2,000 lb	Up to 1" Diameter
USLS-012-PIG	12"	.3 m			
USLS-015-PIG	15"	.4 m			
USLS-018-PIG	18"	.5 m			
USLS-024-PIG	24"	.6 m			

Item Number :	Fiberglass Length:		Diameter:	Load Limit:	Conductor Size:
USLS-006-HOG	6"	.2 m	1.25"	3,500 lb	Up to 1.5" Diameter
USLS-012-HOG	12"	.3 m			
USLS-015-HOG	15"	.4 m			
USLS-018-HOG	18"	.5 m			
USLS-024-HOG	24"	.6 m			

Our BLUE STRIPE® Link Sticks are available in custom lengths. Please contact customer service at (828)-323-8914 for more information.

BLUE STRIPE® Link Stick

Conductor Lift & Swivel Eye

The BLUE STRIPE® Link Stick with Conductor Lift & Swivel Eye is load rated to 1,500 lbs., constructed from 1.25" diameter foam filled fiberglass and accepts conductor sizes up to 1.25" diameter. The Conductor Lift features a one piece machined aluminum frame which has a unique spring loaded gate. The Conductor Lift's gate operates without latches, locks or pins allowing it to quickly and easily clip on to conductors.

Applications include:

- Allows smoother operation while moving along conductors
- Specifically designed for construction, repairs and maintenance on overhead conductors



BLUE STRIPE® Link Stick with Conductor Lift & Swivel Eye

Item Number :	Fiberglass Length:		Diameter:	Load Limit:	Conductor Size:
USLS-012-CL	12"	.3 m	1.25"	1,500 lb	Up to 1.25" Diameter
USLS-024-CL	24"	.6 m			



Heavy Duty Pulley

Allows smoother operation while moving along conductors.



Interested in a customized configuration? Please contact customer service at (828) 323-8914 for more information.

**BLUE STRIPE®
Discharge Hook**

Safely Eliminates a Static Charge



Discharge Hook

Discharge Hook Attachment with Spline End

The Utility Solutions BLUE STRIPE® Discharge Hook safely eliminates a static charge after de-energizing. It is a 1.25" diameter, 4' straight stick made of high performance closed cell foam and includes a tin plated copper "U" hook and 6' of copper cable attached to a 2" aluminum "C" type clamp with serrated jaw.

It is also available as a 1' universal spline attachment which can fit on any length stick.

Item Number :	Description:	Size:		Diameter:
USDH-004	DISCHARGE HOOK	4'	1.2 m	1.25"
USDH-001-SE	DISCHARGE HOOK ATTACHMENT WITH SPLINE END	1'	.3 m	

WARNING: Discharge Hooks are not grounding tools as described by OSHA 1910.269(n) and carry no fault duty rating.

**BLUE STRIPE®
Rescue Hook**

Helps Remove Injured Workers from Hazardous Areas

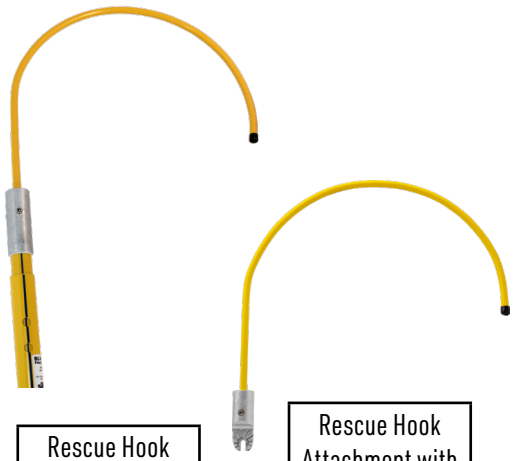

Rescue Hook

Rescue Hook Attachment with Spline End

BLUE STRIPE® Rescue Hooks are available in a fixed model and a telescopic model. The fixed model is made of high performance, 1.25" diameter closed cell foam filled fiberglass and includes a heavy duty rubber boot. The telescopic model has an internal 1.25" diameter closed cell foam filled fiberglass section which collapses into a 1.75" diameter outer section. Two machined buttons secure the Rescue Hook in the open position.

All models use a 18" wide tempered steel hook that is powder-coated in high visibility yellow. The hook separates for freight purposes and convenient storage via the included Allen wrench and fasteners.

The BLUE STRIPE® Rescue Hook Spline option offers flexibility and is compatible with any universal end stick.

Item Number :	Description:	Size:	
USRH-006	STANDARD RESCUE HOOK	6'	1.8 m
USRH-008		8'	2.4 m
USRH-010		10'	3 m

Item Number :	Description:	Size:	
USRH-T-006	TELESCOPIC RESCUE HOOK	6'	1.8 m
USRH-T-008		8'	2.4 m

Item Number :	Description:
USSA-RHS	RESCUE HOOK ATTACHMENT WITH SPINE END

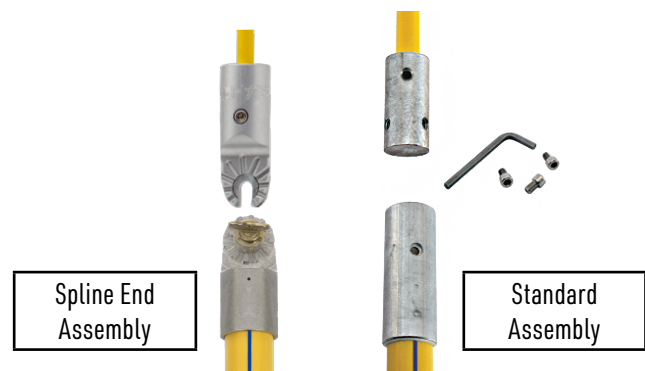

Spline End Assembly

Standard Assembly

**BLUE STRIPE®
Telescopic Stick Stopper**

Quick and Easy Lock System for Telescopic Sticks



Made from durable EPDM rubber, the BLUE STRIPE® Telescopic Stick Stopper attaches to telescopic sticks from 16ft to 50ft. The 3-in-1 design installs in seconds.

- Provides a quick and easy lock system that keeps all sections collapsed.
- Creates a handle for removing from tubes, bins or other hard to reach places.
- Provides surface protection against abrasive storage locations.

Item Number:	Description:	Accommodates Telescopic Sticks Measuring:	
USSA-SS1	STICK STOPPER	16' - 20'	4.8 m - 6.1 m
USSA-SS2		25' - 30'	7.6 m - 9 m
USSA-SS3		35' - 40'	10.7 m - 12.2 m
USSA-SS4		45' - 50'	13.7 m - 15.2 m



**BLUE STRIPE®
Telescopic Range Pole**

Easier Sighting and Measuring



Available in 16', 20', and 25', each BLUE STRIPE® Range Pole includes:

- Contrasting Segments 12" apart for easy sighting and measuring at a distance
- Eyelet tip for attaching flags or ribbon
- Rugged Steel Pointed Base
- Heavy Duty Aluminum Foot

Item Number:	Description:	Size:	
USRP-016	TELESCOPIC RANGE POLE	16'	4.8 m
USRP-020		20'	6.1 m
USRP-025		25'	7.6 m



Spline Torque Bar

Superior Strength, Increased Torque



The Spline Torque Bar allows an operator to apply increased torque at a safe distance to insulated fiberglass hot stick applications. It consists of 1.25" foam filled insulated fiberglass with a foam grip for operator comfort. A specially designed universal end is precision CNC machined from aluminum grade bar stock for superior strength.

Item Number: USSA-STB-018

18" (.5 m) TORQUE BAR SPLINE ATTACHMENT



**BLUE STRIPE®
Cleaning Products**

For Daily Inspection, Wiping, and Cleaning



The BLUE STRIPE® Cloth measures 18" x 18" and imparts a clear protective film of silicone on a hot stick. Our Cloth comes with a durable, resealable clear bag.

BLUE STRIPE® Wipes offer a disposable way of performing light cleaning and protecting your hot sticks with a thin layer of silicone everyday. Our BLUE STRIPE® Wipes come in a convenient dispenser box to mount on the wall.

Both products help comply with the OSHA requirement of daily inspection and wiping of high voltage rated fiberglass hot sticks.

Item Number:	Description:
USTS-SILCLOTH	BLUE STRIPE® CLOTH
USTS-SILWIPE	BLUE STRIPE® WIPES (BOX OF 50)



Carnauba wax repels water and dirt to optimize dielectric properties.

Stay OSHA compliant and extend the life of your hot stick with our BLUE STRIPE® Hot Stick Wax.



An effective neutral cleaner for tools, trucks, fiberglass, painted surfaces, rubber goods and most any non-absorbing surface. Our Blue Stripe® General Purpose Cleaner is pH balanced (non-acid, non-alkali), non-abrasive, biodegradable, non-flammable, non-toxic, mild on skin and does not require ventilation.

Item Number: USTS-WAX

BLUE STRIPE® HOT STICK WAX
14oz CAN

Item Number: USTS-CLEANER

BLUE STRIPE® GENERAL PURPOSE CLEANER
(1 GALLON AS MIXED)

Protective Bags

Fiberglass Stick Storage



Scan for more information.

Utility Solutions offers several different stick bags for storage of our fiberglass stick products. Every bag is water resistant, mold resistant and incorporates a folded end with snap lock. Please visit our website or call customer service for full specs and sizing information.



Item Number:	Description:	Size:
USSB-003	SOFT STICK BAG WITH SNAP	6" WIDE x 36" OAL
USSB-005		6" WIDE x 65" OAL
USSB-006		8.5" WIDE x 78" OAL
USSB-007		6" WIDE x 89" OAL
USSB-008		7.5" WIDE x 72" OAL

Item Number:	Description:	Size:
USSB-009	SOFT STICK BAG WITH SNAP	6" WIDE x 113" OAL
USSB-010		6" WIDE x 100" OAL
USSB-011		6" WIDE x 135" OAL
USSB-012		6" WIDE x 158" OAL

Bucket Stick Storage Cases

Convenient Storage for Buckets and Booms

The Utility Solutions Bucket Stick Storage Case is made from molded polymer and will work with any size bucket stick on the market. The case conveniently clips to the side of the bucket without drilling or bucket modifications.

The Boom Holster is a unique, two-piece hot stick holder that easily mounts on a boom. The rugged molded design is spring loaded at one end so an operator can remove and insert a hot stick with just one hand.

Disconnect and NEMA Switch heads conveniently fit into a slot closest to the operator. With 3 supplied straps, ratchets and rubber pads, the Boom Holster can hold any length stick and adjusts to accommodate different sticks easily.



Item Number:
USBC-001
BUCKET STORAGE CASE

Item Number:
USBC-002
BOOM HOLSTER WITH STRAPS



The Bucket Storage Case accepts bucket sticks up to 12'.

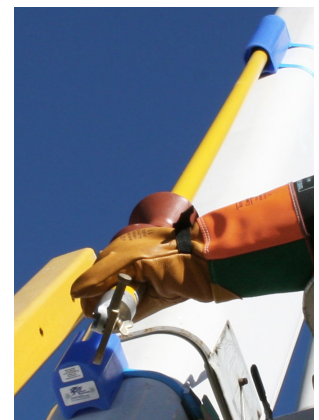

Hot Stick Accessories

Designed for Universal Spline Ends



Scan for more information.

Utility Solutions accessories will fit on a universal Spline End or can be fitted to almost any stick. Accessories are ordered separately by referencing the listed part numbers. Please visit our website to view our entire line of Hot Stick Accessories.



Hand Guard



Camera Mount



Shoestring Cutter

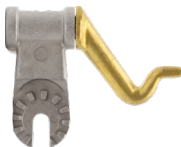

Rotary Prong Spline Attachment



Double Prong Stick End



Hi-Visibility Universal Hot Stick Probe



Universal Hot Stick Probe



Plastic Hook End

Fuzzy Finger™

Hot Stick Probe



Upgrade to the Fuzzy Finger™ hot stick probe, which not only matches all the benefits of a universal hot stick probe but also offers a more secure hold when removing and replacing most standard fuse barrels available on the market.

The Fuzzy Finger™ works on any hot stick universal head and features replaceable nylon bristles that offer a safe and simple method to control a fuse barrel, even in high winds. The Fuzzy Finger™ is machined from lightweight aluminum, making it stronger and more durable than other probes available.

Item Number:	Description:
USSA-FFP	FUZZY FINGER™ PROBE
USSA-FFP-REPAIRKIT	FUZZY FINGER™ REPAIR KIT

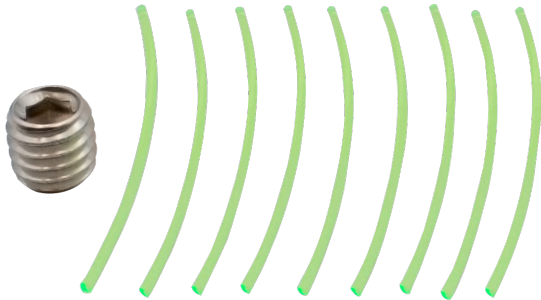

Fuzzy Finger™ Repair Kit with replaceable nylon bristles

Quick Grab Probe & Quick Grab Power Probe

The Ultimate Hotstick Probe



Redesigned and expanded, the new Quick Grab Probe improves on the proven lineman-favorite probe. Incorporating the unique bristle feature from the Fuzzy Finger™ Probe offers broader compatibility and better fuse handling while machined aircraft grade aluminum makes this tool stronger than ever before.

The new Quick Grab Power Probe model features a larger horn which makes locating the pull ring on a power fuse effortless.

Utility Solutions offers an industry-leading Limited-Lifetime Warranty standing by the Quick Grab Probe's exceptional quality.



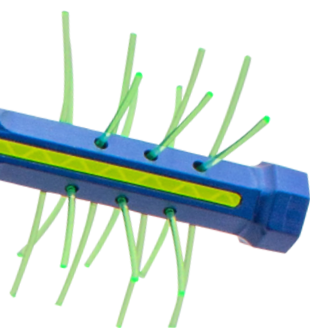

Item Number: USSA-QGP

Quick Grab Probe

Item Number: USSA-QGP-F

Hi-Visibility
Quick Grab Probe

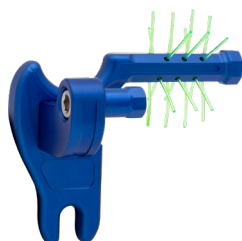

Item Number: USSA-QGP-FFP

Quick Grab
Fuzzy Finger Probe

Item Number: USSA-QGP-FFP-F

Hi-Visibility Quick Grab
Fuzzy Finger Probe

Item Number: USSA-QGP-PWR

Quick Grab
Power Probe



Item Number: USSA-QGP-PWR-F

Hi-Visibility
Quick Grab Power Probe

Item Number: USSA-QGP-PWR-FFP

Quick Grab Power
Fuzzy Finger Probe

Item Number: USSA-QGP-PWR-FFP-F

Hi-Visibility Quick Grab Power
Fuzzy Finger Probe



OVERHEAD DISTRIBUTION

Grab-It™

Cutout Fuse Tube Remover



The Grab-It™ Cutout Fuse Tube Remover offers a fast and safe method of removing and installing overhead fuse barrels. It offers improved control of a fuse barrel, especially in high winds, reducing accidental drops. Made of durable aircraft grade aluminum, it has no moving or plastic parts, ensuring long-lasting trouble-free operation.

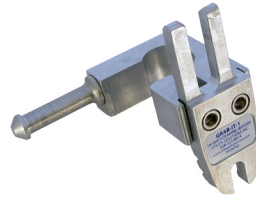

Item Number: GRAB-IT-1
100 AMP CUTOUT FUSE BARREL
REMOVAL TOOL



Item Number: GRAB-IT-2
100 & 200 AMP CUTOUT
FUSE BARREL REMOVAL TOOL



Item Number: GRAB-IT-3
SMU-20 POWER FUSE
REMOVAL TOOL



Item Number: GRAB-IT-4
100 AMP DOUBLE BAR CRADLE
FUSE TUBE REMOVAL TOOL



Item Number: GRAB-IT-5
CURRENT LIMITING (CL)
CUTOUT FUSE REMOVAL TOOL

Options:



Item number:
-F
HI-VISIBILITY COATING

Jack Jumper®

Cutout Bypass Tool



The Jack Jumper® Cutout Bypass Tool offers a fast and safe method of bypassing cutouts when changing fuses or during fuse coordination. The tool works by jumping the cutout from top to bottom, allowing fuse removal without service interruptions. The Jack Jumper® installs and removes in seconds using a shotgun stick, saving time and money. 9 models are available to work with most cutout styles available.

- All Jack Jumper® tools are rated at 100 Amps.

Non Load Break



Item number: USJJ-001-S
15 kV CUTOUT WITH SOFT CASE



Item number: USJJ-002-S
27 kV CUTOUT WITH SOFT CASE

Load Break



Item number: USJJ-003-S
CHANCE 15 kV LOADBREAK CUTOUT WITH SOFT CASE



Item number: USJJ-004-S
ABB 15 kV LOADBREAK CUTOUT WITH SOFT CASE

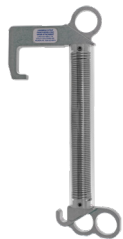

Item number: USJJ-008-S
CHANCE 27 kV LOADBREAK CUTOUT WITH SOFT CASE

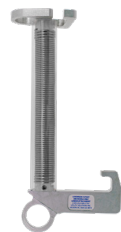

Item number: USJJ-009-S
ABB 27 kV LOADBREAK CUTOUT WITH SOFT CASE

Jack Jumper®

Cutout Bypass Tool

Non Load Break



Item number: USJJ-005-S

S&C SMD-20 15 kV, EATON 24CMU POWER FUSES & 38 kV CUTOUT WITH SOFT CASE



Item number: USJJ-006-S

S&C SMD-20 27 kV & EATON S9CMU POWER FUSE WITH SOFT CASE



Item number: USJJ-007-S

S&C SMD-20 35 kV POWER FUSE WITH SOFT CASE



The Soft Case offers perfect protection for all Jack Jumper products.

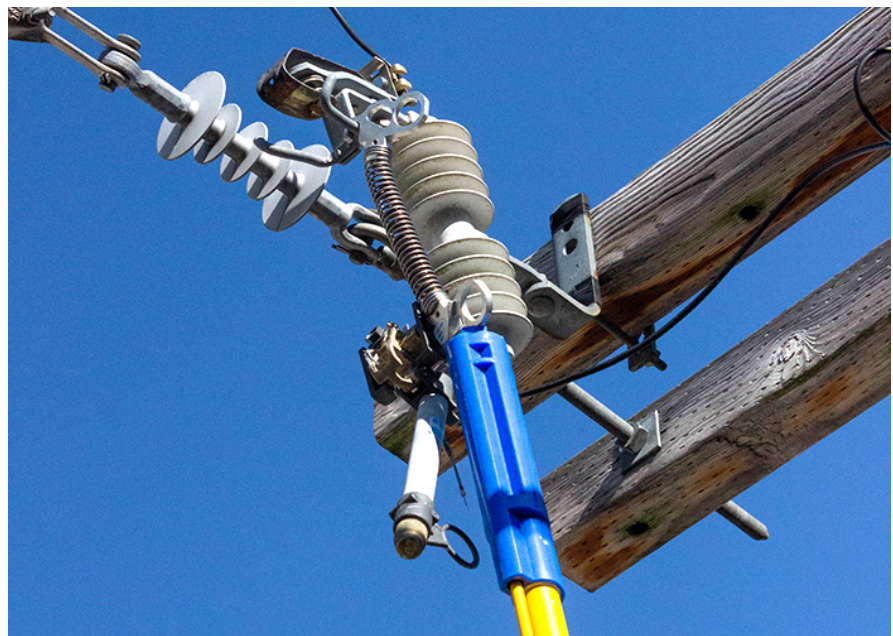

Conductor Lift Snatch Block

Heavy-Duty Pulley for Overhead Conductors



Item Number:	Description:
USCL-001	CONDUCTOR LIFT SNATCH BLOCK
USCL-001-SH	CONDUCTOR LIFT SNATCH BLOCK WITH BOLT SHACKLE

The Conductor Lift Snatch Block is a compact, heavy-duty pulley designed for overhead conductor work. Made from solid aluminum, its unique spring-loaded gate allows easy conductor attachment without latches or pins, improving safety and ease of use compared to conventional snatch blocks.

- 1500 lb working load
- Supports conductors up to 1500 MCM, 1033.5 ASCR or 1.25" dia.
- The Conductor Lift is now available as a link stick configuration.



Tail Tamer™

Temporary Conductor Clamp



The Tail Tamer™ Temporary Conductor Clamp is a tool for safely controlling conductors during construction and maintenance tasks. The patented design serves as a double clamp, allowing two conductors to be cinched at once.

The Tail Tamer™ serves multiple purposes during stringing, cutting, and connecting operations. The Tail Tamer™ is rated at continuous current rated 300 amps and load rated at 200 lb.

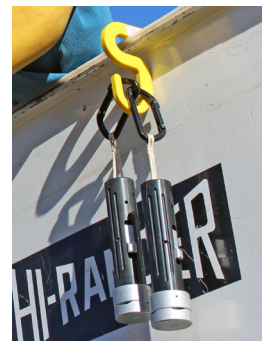

Item Number: USTT-001

TAIL TAMER™ TEMPORARY CONDUCTOR CLAMP

Jumper-T

Parking Stand for Temporary Mechanical Jumpers

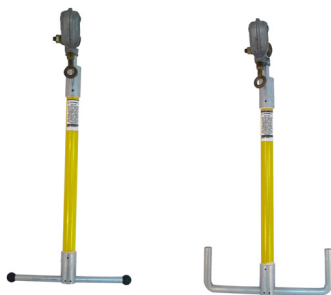

The Jumper-T Parking Stand is an insulated stand designed for parking temporary mechanical jumpers. The Jumper-T features 15" of 1.25" foam filled fiberglass and can combine shorter jumpers for extended reach or can be used to park jumpers to create a visible air gap.

This tool can also be used with the Break-Safe® to create a visible air gap. Available in straight or bent configurations, it can eliminate jumper sag and cross-phasing risks.

The Jumper-T is rated for 300 Amps continuous current, with the duckbill clamp accommodating #6 copper up to 1033 MCM.

Customized lengths are available. Please contact customer service for more information.

Item Number:	Description:
USJT-001	JUMPER-T STRAIGHT BAR
USJT-002	JUMPER-T BENT BAR

Conductor Cleaning Brush

Heavy Duty, 360-Degree Conductor Cleaning Tool

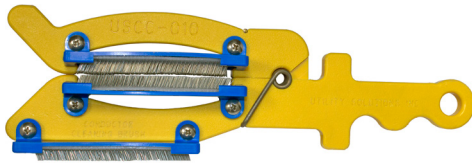

USCC-010

The patented Conductor Cleaning Brush offers a thorough and user-friendly method of brushing conductors and bushings. Providing 360-degree cleaning and shotgun stick compaibility, its flexible pads conform to various conductor sizes, while an external brush allows traditional cleaning on flat surfaces. The tool offers easy pad replacement, no tools required. The Conductor Cleaning Brush is constructed from weather-resistant polymer and features spring-loaded jaws that ensure durability and effective cleaning.

Item Number:	Description:
USCC-010	1/8"-3" CONDUCTOR CLEANING BRUSH
USCC-010-PADS	REPLACEMENT PAD SET FOR #USCC-010 (3)
USCC-011	3"-11" CONDUCTOR CLEANING BRUSH
USCC-011-PADS	REPLACEMENT PAD SET FOR #USCC-011 (3)



USCC-011



Replacement Pads

Varmint Shield

Round Animal Guard



The Varmint Shield is a durable animal guard for insulators, easily installed with a hot stick. Made from a flame retardant and UV-stabilized polymer, it withstands extreme weather without becoming brittle. Molded indicator markings allow customization for insulators or bushings from 1.75" to 6". It effectively prevents energized connections and ensures critters go around the guard, suitable for various distribution systems and high voltage bushings.

Item Number:	Description:
USVS-001	16" GRAY VARMINT SHIELD
USVS-002	16" RED VARMINT SHIELD

Item Number:	Description:
USVS-003	20" GRAY VARMINT SHIELD
USVS-004	20" RED VARMINT SHIELD



Expendable Fuse Tube Caps

Compatible with 100 and 200 Amp Fuse Tubes

Utility Solutions' Expendable Fuse Caps adhere to ANSI C37.42 design criteria for thread pitch and venting pressure. Compatible with 100 and 200 Amp fuse tubes, these caps are stamped with an "E" on the button head. The USCO-062 & USCO-063 models feature a "stove pipe" design, ensuring vertical gas expulsion for close horizontal phase-to-phase construction.



Item Number: USCO-060
100 AMP STANDARD EXPENDABLE FUSE TUBE CAP



Item Number: USCO-061
200 AMP STANDARD EXPENDABLE FUSE TUBE CAP



Item Number: USCO-062
100 AMP STOVEPIPE EXPENDABLE FUSE TUBE CAP



Item Number: USCO-063
200 AMP STOVEPIPE EXPENDABLE FUSE TUBE CAP

BLUE STRIPE® Heavy Duty Ice Roller

Safely Remove Ice From Overhead Lines

The BLUE STRIPE® Heavy Duty Ice Roller is a ground-based system for safely removing ice from overhead lines. Its aluminum roller accommodates ice-coated conductors up to 1.75" diameter. With a non-impact design, it protects both insulated and non-insulated conductors and is easy to transport and store. Choose the reliable BLUE STRIPE® Heavy Duty Ice Roller for efficient and safe ice removal.



Item Number:	Description:
USIR-001	ICE ROLLER HEAD
USIR-002	ICE ROLLER PULL RING
USIR-005	ICE ROLLER, 5' STICK EXTENSION
USIR-010	ICE ROLLER, 10' STICK EXTENSION

Item Number:	Description:
USIR-005-CA	ICE ROLLER, 5' STICK EXTENSION W/ ROLLER HEAD & EYE NUT ASSEMBLY
USIR-010-CA	ICE ROLLER, 10' STICK EXTENSION W/ ROLLER HEAD & EYE NUT ASSEMBLY



Ice Roller Head



Ice Roller Pull Ring



Don't wait until it's too late to be prepared for winter storms!

Ice Breaker**Ice Removal Spline End Attachment**

Item Number: USSA-IBH

ICE BREAKER - SPLINE END ATTACHMENT

The Ice Breaker is a compact, universal-end option for ice removal. This Spline End Attachment accommodates conductors up to 1.1" dia.

**Ice Whacker****Polymeric Ice Removal Tool**

Item Number: USSA-ASD

Length:

POLYMERIC ICE REMOVAL TOOL

19"

The Ice Whacker is a polymeric ice removal tool that offers a simple and satisfying method of removing ice from frozen conductors. The Ice Whacker is designed to prevent hot sticks from taking damage when removing ice from overhead lines



Jumper Hook

Temporary Jumper Lead Hanger



The Jumper Hook provides a simple means of eliminating jumper sag without the use of tape or rope.

The Jumper Hook will fit over any class 2 or 3 line hose and has a flash over resistance of 50kV.

The Jumper Hook is made from hi-performance polymer and installs in seconds, either manually or by shotgun stick.

Item Number: USJH-001

POLYMERIC JUMPER HOOK

Jumper Aid™

Temporary Mechanical Jumper Support



The Jumper-Aid™ eliminates jumper sag with a pivoting design that is large enough to fit over most cross arms and positively captures jumpers and blankets.

The Jumper-Aid™ is machined from hi-performance polymer and can be installed manually or by shotgun stick.

Item Number: USJH-002

POLYMERIC JUMPER-AID

Jumper Cuff™

Temporary Mechanical Jumper Holder



The Jumper Cuff™ features a patented V-Notch design that securely holds jumpers, preventing sliding. The Jumper Cuff™ is machined from high-performance polymer and easily fits over bare conductors and class line hose up to 2.5" OD.

The Jumper Cuff™ installs or removes in seconds, by hand or shotgun stick.

Item Number: USJH-003

JUMPER CUFF™ - TEMPORARY JUMPER HOLDER

Blanket Mate

Heavy Duty Blanket Holder



The Blanket Mate Heavy Duty Blanket Holder is designed to secure insulating blankets to magnetic surfaces such as transformers, both padmount and overhead.

The unique segmented design allows it to conform securely to curved surfaces.

The Blanket Mate Heavy Duty Blanket Holder is available in a 6 or 8 magnet option and comes with a 5 year warranty.



Item Number:	Description:
USBM-001	BLANKET MATE 6 MAGNET BLANKET ANCHOR
USBM-002	BLANKET MATE 8 MAGNET BLANKET ANCHOR



Bucket Hook

High Performance Bucket Hook



The Bucket Hook Polymeric Hook is a machined, high-performance alternative to traditional molded hooks.

The interior hook accommodates tool bags, while the exterior hook fits blanket holes without damaging them. The Bucket Hook is also available in a Wide Slot for lined buckets. The Bucket Hook is equipped with a 5-year warranty and a 75 lb weight capacity.



Item Number:	Description:
USBM-004	POLYMERIC BUCKET HOOK
USBM-004-W	WIDE SLOT POLYMERIC BUCKET HOOK



Blanket Clamp

Insulating Blanket Clothespins



The Blanket Clamp aids in securely placing insulating rubber blankets on poles, lines, and other work surfaces. The Blanket Clamp features rubber end caps to prevent blanket damage.

The Blanket Clamp is available in hand operable or shotgun operable options.

Item Number:	Description:
USBA-001	BLANKET CLAMP
USBA-002	BLANKET CLAMP SHOTGUN OPERABLE

KLONDIKE CLAMP®

Saves Time and Prevents Damage to Rubber Goods



The KLONDIKE CLAMP® ensures hassle-free, secure attachment of rubber blankets without the use of tape or rope. Its ergonomic design with lineman-friendly grip and extended handles offers better control, while the strong clamping force and flared opening allow for easy one-handed operation. The KLONDIKE CLAMP® is available in 3 models:

- Standard - For crossarms, bushings and poles up to 11" diameter.
- Large - Fits larger poles from 11" to 20" in diameter.
- Hands-Free - Shotgun operable for hands-free operation.



Item Number: USCP-001
 KLONDIKE CLAMP®
 INSULATING BLANKET
 CLOTHESPIN



Item Number: USCP-002
 OVERSIZED KLONDIKE CLAMP®
 INSULATING BLANKET
 CLOTHESPIN



Item Number: USCP-004
 SHOTGUN OPERABLE KLONDIKE
 CLAMP® INSULATING BLANKET
 CLOTHESPIN

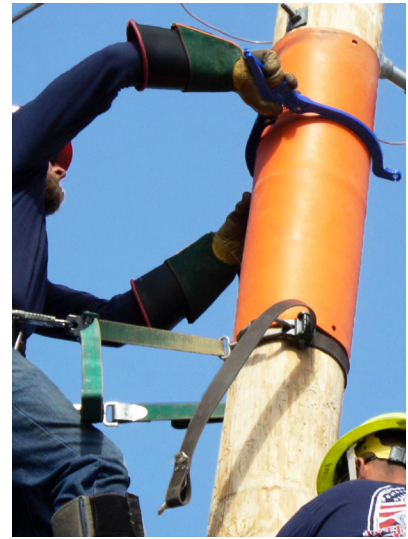

Allievates problems like sticky tape residue and is quicker and less cumbersome than using rope.

Rex Clamp™

Adjustable Control for Conductor Tails and Strap Hoists



The Rex Clamp™ is designed to safely and securely control a loose tail when using a come along or strap hoist. This clamp is suitable for conductor sizes up to 1.15" OD and can accept straps up to 3" wide.

The patent-pending design features a rotating arm to positively capture the tail and strap in place while still allowing the clamp to slide.

The Rex Clamp™ is machined from high-performance polymer.



Item Number: USRC-001
 REX CLAMP™





UNDERGROUND DISTRIBUTION

BLUE STRIPE® Switch Hook Stick

Heavy-Duty Switching Applications

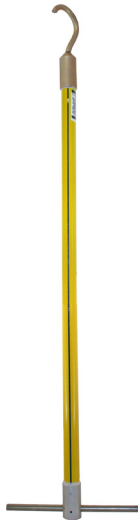

The Switch Hook Stick is a heavy-duty alternative to a standard Shotgun stick when actuating sectionalizing loadbreak switches, or when high torque switching applications are required. The stick is constructed from 1.25" closed cell, foam-filled fiberglass, features a 3.5" dichromate-coated steel hook that aligns with our BLUE STRIPE®, and ends in a stainless steel T-handle or an optional spline end.

The BLUE STRIPE® Switch Hook Stick is available in custom lengths. Contact customer service for more information.

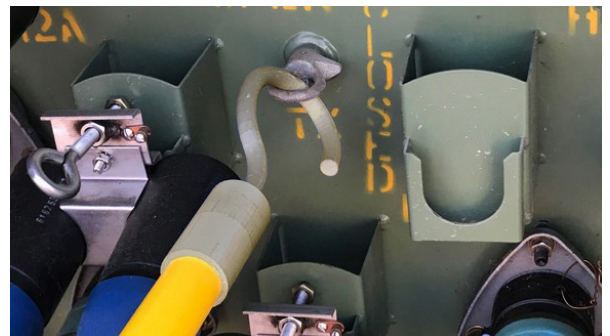

Item Number:	Description:
USSH-004	4' BLUE STRIPE® SWITCH HOOK STICK
USSH-006	6' BLUE STRIPE® SWITCH HOOK STICK
USSH-008	8' BLUE STRIPE® SWITCH HOOK STICK

Item Number: USSH-XXX-SE
OPTIONAL SPLINE END

BLUE STRIPE® Cable Hook Stick

Safe & Secure Handling of Installed Underground Cables



The Cable Hook Stick enables safe and secure handling of installed underground cables. The high-visibility, tempered steel 5" hook aligns with our BLUE STRIPE® for improved visibility and cable handling.

The stick is constructed from 1.25" closed cell, foam filled-fiberglass and features a stainless steel T-handle or an optional shovel handle.

The BLUE STRIPE® Cable Hook Stick is available in custom lengths. Contact customer service for more information.



Item Number:	Description:
USCH-004	4' BLUE STRIPE® CABLE HOOK STICK
USCH-006	6' BLUE STRIPE® CABLE HOOK STICK
USCH-008	8' BLUE STRIPE® CABLE HOOK STICK

Item Number: USCH-XXX-SH
OPTIONAL SHOVEL HANDLE

URD Cap Stand™

Portable Insulated Cap Holder



The URD Cap Stand™ provides a simple and secure means of holding insulated caps when working with padmount transformers or switch gear. The adjustable design fits snugly over padgear lips up to 2" wide, keeping the work area clear. The URD Cap Stand™ is available in single, dual or triple arm options. The dual and triple arm models have a convenient shotgun attachment.



Item Number: USUC-001

URD CAP STAND™
SINGLE CAP HOLDER



Item Number: USUC-002

URD CAP STAND™
DOUBLE CAP HOLDER



Item Number: USUC-003

URD CAP STAND™
TRIPLE CAP HOLDER

Strip-N-Coil™

Heavy-Duty Underground Cable Stripper

The Strip-N-Coil™ is a heavy-duty cable stripper designed for underground cable sizes from #2 through 750 MCM.

The Strip-N-Coil™ is made from hardened, dichromate-coated steel. The tool fits drills and impact drivers with a 7/16" quick change chuck. The Strip-N-Coil™ does not use blades or require adjustments.



Item Number: USCS-001

STRIP-N-COIL™ CABLE STRIPPER



Padmount Multi-Tool

Heavy Duty 4-way Padmount Wrench



Item Number: USMT-001

PADGEAR ACCESS MULTI-TOOL

The Padmount Multi-Tool is a heavy-duty, 4-in-1 pad gear socket wrench including:

- 3/4" Socket
- ANSI penta-head socket
- 9/16" Deep-well socket
- Drag Link socket

The wrench body is constructed of chrome-plated steel. The low-profile lug wrench design can apply substantial torque while still allowing access to bolts in hard-to-reach locations.



Universal URD Wrench

Multi-Functional Tool For Electrical And Water Personnel



Item Number: USUW-001

UNIVERSAL URD WRENCH

The Universal URD Wrench features an inline handle including both an ANSI penta-head and a 3/4" socket. The stainless-steel shaft measures 10.5" and is tipped with a flathead driver and a 90° hook. The Universal URD Wrench can be used for:

- Opening pad gear locks
- Lifting manhole covers
- Prying rusty or stuck pad gear



Penta Head



3/4" Socket

Padmount Hex Adapter Set

Easy Access In Tight Spaces



Item Number: USMT-PHA

PADMOUNT HEX ADAPTER SET



The Padmount Hex Adapter Set provides a simple and robust means of accessing hard-to-reach bus bar lugs found within URD padmounted gear. Each set includes a 3/4" driver with a 3/8" Allen head shank size and 3/4" driver with a 5/16" Allen head shank size. The set works with any 3/4" open box or socket wrench.

The adapters are constructed from hardened dichromate-coated steel and are equipped with a 5 year warranty.





METERING PRODUCTS

Meter Grabber

Superior Protection



Item Number: USMG-001

SINGLE & THREE PHASE
METER REMOVAL &
INSTALLATION TOOL

The Utility Solutions Meter Grabber is an essential tool for electric meter installation and removal. It provides superior protection from hazards due to a fault. With no metal components around the working end, operator protection is paramount. Side slots permit venting during a fault.

The unique clamshell design allows installation and removal on most single and multiphase meters. A sliding arm positively captures the meter, providing leverage for stubborn meters as well as minimizing accidental drops. The Meter Grabber is molded from a tinted rugged polymer which allows improved visibility to the operator.

Two models are available, one with and one without a clear polymer arc shield. The Meter Grabber with arc shield rings is optional for additional operator safety. The arc shield provides an extra layer of protection and shielding against a fault.



Item Number: USMG-002

SINGLE & THREE PHASE METER
REMOVAL & INSTALLATION TOOL
WITH ARC SHIELD



Item Number:	Description:
USMG-001-BAG	CARRYING CASE FOR USMG-001
USMG-002-BAG	CARRYING CASE FOR USMG-002

Electric Meter Jumper Leads

Convenient and Safe



Item Number: USJL-001

ELECTRIC METER JUMPER LEAD SET
(FERRULE CONNECTION)

Our Electric Meter Jumper Lead sets are a convenient and safe method to prevent a customer outage during a meter removal or change-out. They are constructed from #6 AWG highly flexible insulated copper. Leads are available with a 100 AMP breaker option (USJL-002). The resettable single pole 240 volt hydraulic breaker allows for added safety and protection of property.



Item Number: USJL-002

ELECTRIC METER JUMPER LEAD SET WITH
100 AMP BREAKERS (FERRULE CONNECTION)



Item Number: USMG-001-BAG

CARRYING CASE FOR
USJL-001

SERVICES

Tool Demonstration Trailers and Trucks

- Utility Solutions, Inc. tool demonstration trailers and trucks are located throughout North America.
- The trailers and trucks offer our entire line of products and a unique interactive environment to both inform and educate linemen.
- Call your local Territory Manager to schedule a visit in your area.



Factory Repair Service

- Utility Solutions, Inc. offers Factory Certified Repair services for our Load Break tools. Repairing these products requires unique skills, parts and tools that are offered by our factory. This ensures the safest and most reliable tools are in the field and ready for live line work.
- Benefits:
 - Factory Trained Professionals
 - Safety
 - Fast Service
 - Extended Warranty
- Visit our website to print and fill out a Repair Service Form or to submit an online Repair Service Form.

TERMS & CONDITIONS

Standard Terms and Conditions of Sale

These terms and conditions govern the sale of products ("Product or Products") and provisions of services ("Services") by Utility Solutions Inc. (USI). These terms and conditions ("Agreement") take precedence over Buyer's supplemental or conflicting terms and conditions to which notice of objection is hereby given. Neither Seller's commencement of performance or delivery shall be deemed or construed as acceptance of Buyer's supplemental or conflicting terms and conditions. USI's failure to object to conflicting or additional terms will not change or add to the terms of this agreement. Buyer's acceptance of the Products and / or Services from Seller shall be deemed to constitute acceptance of the terms and conditions contained herein.

- 1. Orders:** All orders placed by Buyer are subject to acceptance by Seller. Orders may not be cancelled or rescheduled without the Seller's consent. All orders must identify the product, part number, quantity, unit price, freight forwarder, contact information, Bill and Ship To information as well as purchase order number, date and quotation reference if applicable. Seller may at its sole discretion allocate Product among its customers.
- 2. Prices:** The prices of the Products are those specified through price list or quotation. Pricing is subject to change in the event of an increase in Seller's cost, change in market conditions or any other causes beyond Seller's control. Price quotations shall automatically expire in thirty (30) days from date of issue, or as otherwise stated in the quotation.
- 3. Taxes:** Unless otherwise agreed to in writing by Seller, all prices quoted are exclusive of transportation and insurance costs, duties, and all taxes including federal, state and local sales, excise and value added, goods and services taxes, and any other taxes. Buyer agrees to indemnify and hold Seller harmless for any liability for tax in connection with the sale, as well as the collection or withholding thereof, including penalties and interest thereon.
- 4. Payment:** Payment may be made by check, money order, credit card, or wire transfer (all fees are borne by the buyer). Where Seller has extended credit to the Buyer, terms of payment shall be net thirty (30) days from date of invoice. On any past due invoice, Seller may impose interest at the rate of 1.5% per month. If Buyer fails to make each payment when it is due, Seller reserves the right to change or withdraw credit and hereby suspend or cancel performance under any and all purchase order agreements in which Seller has extended credit to the Buyer. In the event of default by Buyer, Seller shall be entitled to costs, fees, and expenses, including but not limited to recover of attorney fees, court costs and fees, and collection costs.
- 5. Delivery and Title:** All deliveries shall be made "EXWORKS" place of shipment, unless otherwise agreed upon, and all sales shall be considered final at time of delivery. Title and risk of loss pass to the Buyer upon delivery of the Product to the carrier. Seller's delivery dates are estimates only and Seller is not liable for delays in delivery or for failure to perform due to causes beyond the reasonable control of the Seller, nor shall carrier be deemed an agent of the Seller. A delayed delivery of any part of an order does not entitle Buyer to cancel other deliveries. Deliveries within four (4) weeks of scheduled date shall be considered firm and cannot be modified without acceptance from the Seller.
- 6. Acceptance / Returns:** Shipments will be deemed to have been accepted by the Buyer upon delivery of the said shipments to the Buyer unless rejected upon receipt. Any discrepancy in shipment quantity must be reported within 7 days after delivery. Buyer may not return Products without a return for material authorization (RMA). RMA valid for 30 days from date issued. Any product returned by Buyer due to Buyer's error may be subject to a restocking charge equivalent to 50% of the value of such Product as specified in Seller's invoice to Buyer, and total returns shall not exceed 5% of Buyer's annual sales. Special orders may not be subject to return. USI reserves the right to refuse RMA requests for any reason.
- 7. Limited Warranty:** Seller warrants to Buyer that Products purchased hereunder will conform to the manufacturer's specifications for such products and is warranted from material defect for a period of one (1) year from the date of shipment. If Seller breaches this warranty, Buyer's remedy is limited to (at Seller's election) (1) refund of Buyer's purchase price for such production (without interest), (2) repair of such Products, or (3) replacement of such Products; provided that such Products must be returned to Seller, along with acceptable evidence of purchase. No warranty will apply if the Product has been subjected to misuse, neglect, accident or modification. **SAVE AS EXPRESSLY PROVIDED IN THESE TERMS AND CONDITIONS, ALL IMPLIED WARRANTIES, TERMS AND CONDITIONS (WHETHER STATUTORY OR OTHERWISE) ARE EXCLUDED TO THE FULLEST EXTENT PERMITTED BY LAW.**
- 8. Limitation of Liabilities:** BUYER SHALL NOT BE ENTITLED TO, AND SELLER SHALL NOT BE LIABLE FOR, LOSS OF PROFITS OR REVENUE, PROMOTIONAL OR MANUFACTURING EXPENSES, OVERHEADS, BUSINESS INTERRUPTION COSTS, INJURY TO REPUTATION OR LOSS OF BUYERS, PUNITIVE DAMAGES, LOSS OF CONTRACTS OR ORDERS OR ANY INDIRECT, SPECIAL INCIDENTAL OR CONSEQUENTIAL DAMAGES OF ANY NATURE. BUYER'S RECOVERY FROM SELLER FOR ANY CLAIM SHALL NOT EXCEED THE PURCHASE PRICE PAID FOR THE AFFECTED PRODUCTS IRRESPECTIVE OF THE NATURE OF THE CLAIM WHETHER IN CONTRACT, TORT, WARRANTY OR OTHERWISE. BUYER WILL INDEMNIFY, DEFEND AND HOLD SELLER HARMLESS FROM ANY CLAIMS BASED ON (a) SELLER'S COMPLIANCE WITH BUYER'S DESIGNS, SPECIFICATIONS, OR INSTRUCTIONS, (b) MODIFICATION OF ANY PRODUCTS BY ANYONE OTHER THAN SELLER, OR (c) USE IN COMBINATION WITH OTHER PRODUCTS.
- 9. Export Control:** Buyer certifies that it will be the recipient of the Products to be delivered by the Seller. Buyer acknowledges that the products are subject to the export/import control laws and regulations of various countries, including the Export Administration Laws of the United States. Products sold by the Seller cannot be transferred, sold or re-exported to any part on the Entity List or Restricted Persons List of the U.S. Department of Commerce Bureau of Industry and Security, any party designated by the U.S. Department of Treasury Department's Office of Foreign Assets Control, and any party debarred or sanctioned for proliferation of terrorism reasons by the U.S. State Department.
- 10. Use of Products:** Buyer agrees that Seller and manufacturer of the Products are not liable, in whole or in part, for any claim. Buyer agrees to indemnify, defend and hold seller and manufacturer of Products harmless from and against any and all claims, damages, losses, costs, expenses, and liabilities arising out of or in connection with use or sale.
- 11. Force Majeure:** Seller is not liable for failure to fulfill its obligations for any accepted order or for delays in delivery due to causes beyond Seller's reasonable control including, but not limited to, acts of God, natural or artificial disaster, riot, war, strike, delay by carrier, shortage of product, acts or omissions of other parties, acts or omissions of civil or military authority, Government priorities, changes in law, material shortages, fire, floods, epidemics, quarantine restrictions, acts of terrorism, delays in transportation or inability to obtain labor, materials or products through its regular sources, which shall be considered as an event of force majeure excusing Seller from performance and barring remedies for non-performance. In an event of force majeure condition, the Seller's time for performance shall be extended for a period equal to the time lost as a consequence of the force majeure condition with subjecting Seller to any liability or penalty. Seller may, at its option, cancel the remaining performance, without liability or penalty, by giving notice of such cancellation to the Buyer.
- 12. Technical Assistance or Advice:** Any technical assistance or advice offered to the Buyer is provided only as an accommodation to the Buyer. Seller shall not be held liable for the content or Buyer's use of such technical assistance or advice nor shall any statement made by any of Seller's representatives in connection with the Products or Services constitute a representation or warranty, express or implied.
- 13. General:** (a) The laws of the state of North Carolina will exclusively govern any dispute between Seller and Buyer, (b) Buyer may not assign this Agreement without the prior written consent of the Seller. This agreement is binding on successor and assigns, (c) Products, including intellectual property, are subject to any applicable rights of third parties, such as patents, copyrights and/or user licenses.

VIDEO LIBRARY

Load Break Tools

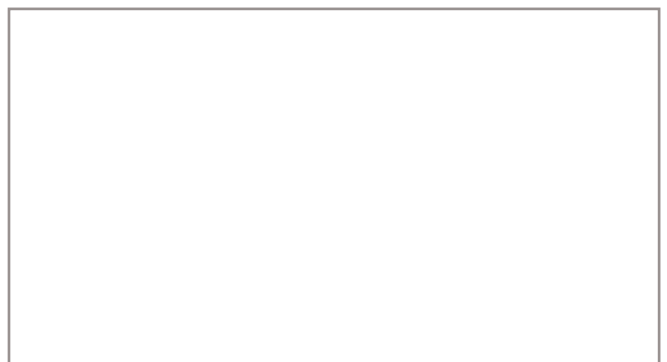
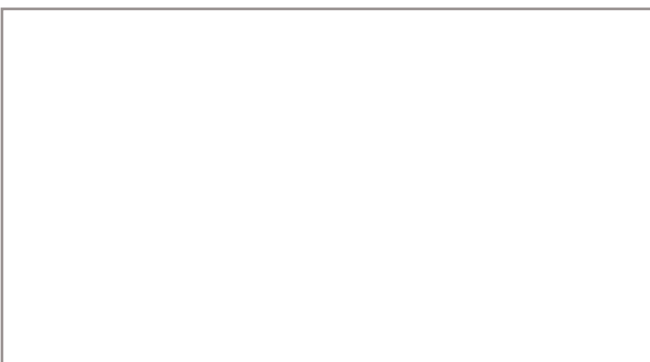
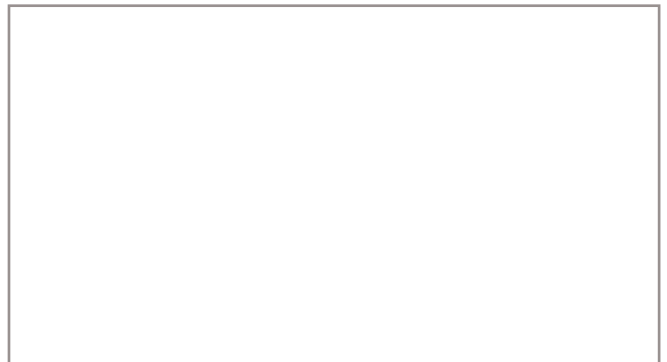

VIDEO LIBRARY

Load Break Tools



VIDEO LIBRARY

Safety & Training

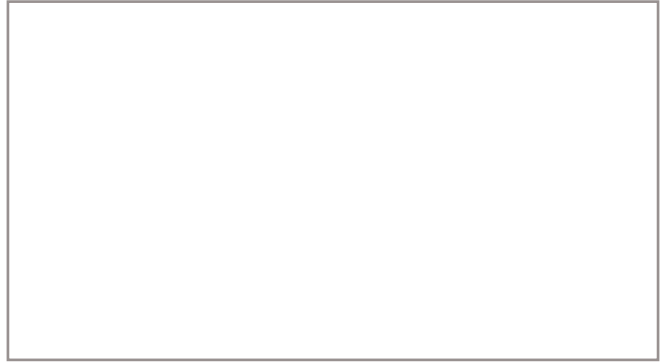
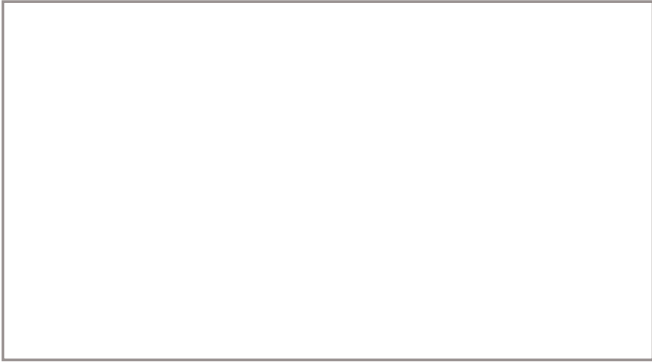

Fiberglass Hot Sticks

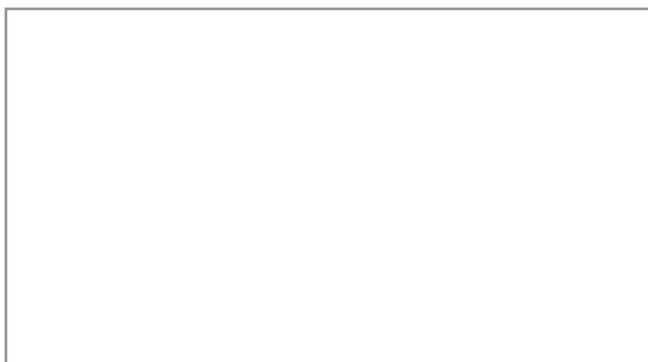
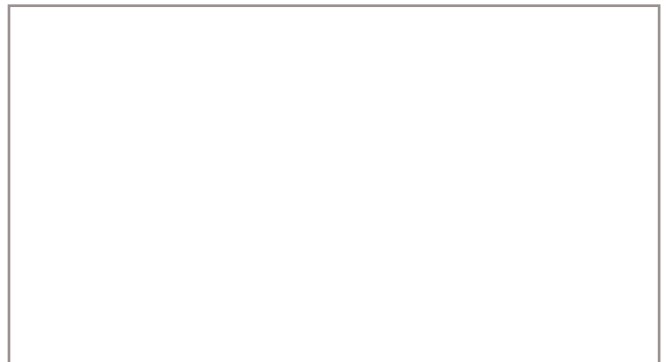
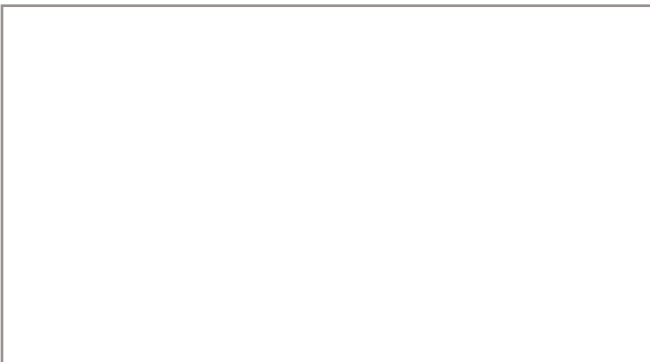

Overhead Distribution

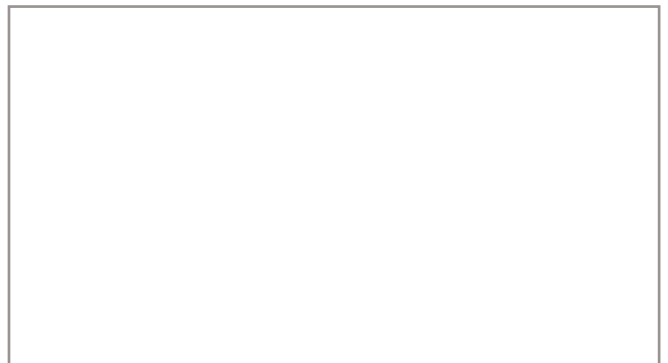
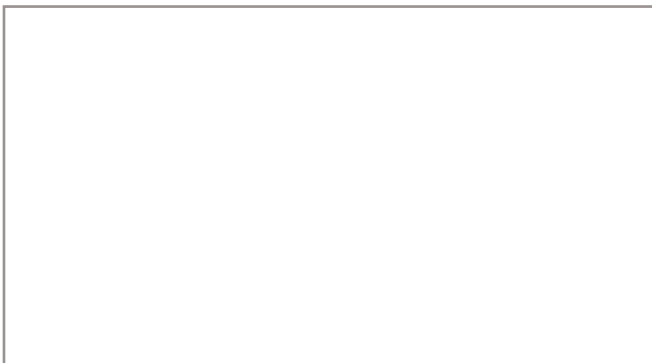

Underground Distribution

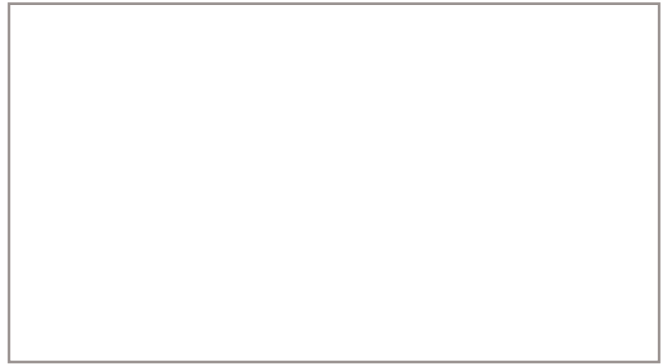

VIDEO LIBRARY

Metering Products



Demo Trucks

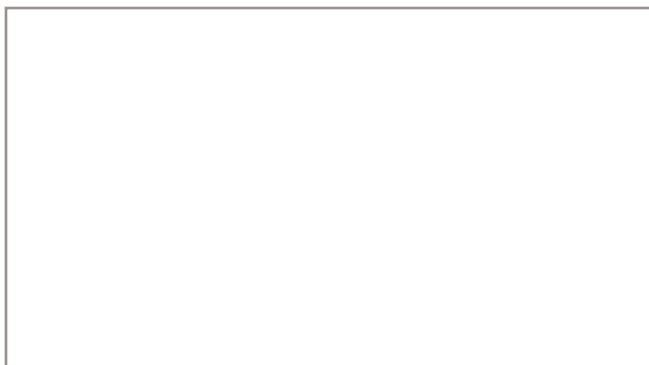





101 33rd Street Drive SE
Hickory, NC 28602

